

LAVATEC

Laundry Technology GmbH

SPARE PARTS LIST

LAVATRAC

MODELLE

LT 25-BT

LT 35-BT

LT 50-BT

LT 60-BT

LT 70-BT

LT 90-BT



**SERIAL N°
WIRING DIAGRAM**

LAVATEC
Laundry Technology GmbH
Wannenäckerstraße 53
D – 74078 Heilbronn
Telefon 0 71 31 / 29 80
www.lavatec-laundry.de

ET-LT_V13.01.07_GB

9.0 PARTS LIST

ORDERING SPARE PARTS

In case spare parts are needed, please include the following information with your order :

1. Model and serial number of the equipment (located on the name plate).
2. Part number, part name, and quantity required. Use this manual to facilitate ordering.
3. When ordering electrical motors, please include complete name plate data, motor manufacturer, and wiring diagram number.

Our service and spare parts department consists of specially trained personnel to assist you with your needs. Please do not hesitate to call if we can be of any assistance to you.

SUBJECT TO CHANGES WITHOUT NOTIFICATION

9-0.1 INDEX

	Page
Control cabinet (separate)	9-1.0
Video-terminal (PROVIT 2000)	9-1.2
»LAVATRAC«, Loading side, in case of separate control cabinet	9-2.0
»LAVATRAC«, Loading side, with integrated control cabinet	9-2.2
Water tank	9-3.0
Heating for water tank	9-3.2
Reversing valve, water tank	9-3.5
Drive assembly	9-4.0
Drum wheels assembly	9-5.0
Central support	9-6.0
Drum axial bearing	9-7.0
Drum limit switch	9-8.0
Reversing control	9-9.0
Temperature control / liquor tank heating (double drum area)	9-10.0
Parts of steam line	9-10.3
PH-control	9-11.0
Measuring vessel for PH-control	9-11.2
PH-control in the double drum area	9-11.4
Water pump	9-12.0
Water control system	9-13.0
Water pressure control	9-14.0
Water flow control	9-15.0
Water system fittings	9-16.0
Sampling system	9-17.0
Rinse water inlet Manifold	9-18.0
Injector assembly, unloading side	9-19.0
Dosing manifold	9-20.0
Level control, weir box	9-21.0
Level control, weir box, pneumatic	9-21.4
Level control of washing tank, conductive	9-22.0
Drain valve assembly	9-23.0
Seals, rubber, drum/liquor tank	9-24.0
Pneumatic system until 31.05.2010	9-25.0
Automatic lint separator »LAVALINT«	9-26.0
Control panel dosing	9-27.0
Dosing system detergent	9-28.0
Dosing system starch	9-29.0
Dosing system, auxiliary chemicals	9-30.0
Pneumatic system from 2010-06	9-31.0

TYPE LT 25 , LT 35
LT 50 , LT 60
LT 70 , LT 90

Parts Manual

CONTROL CABINET
separate design

Page
9-1.0

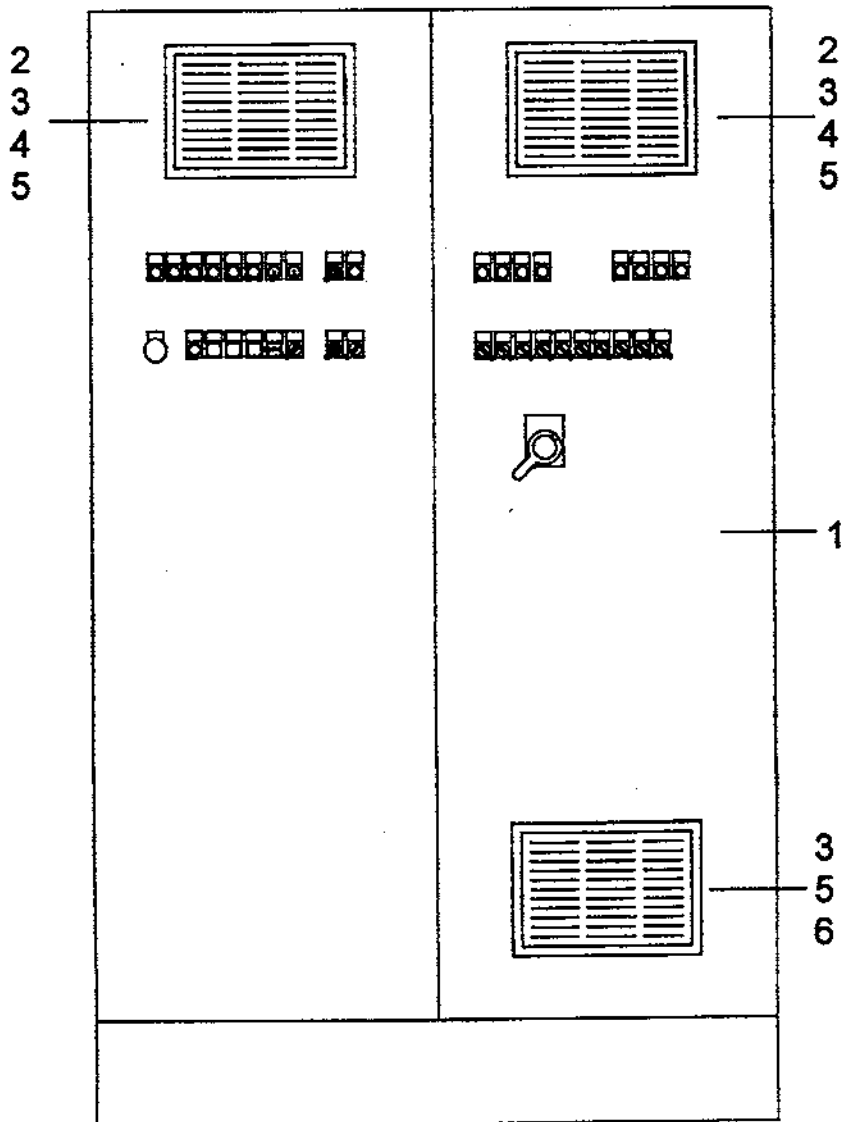

TYPE		Parts Manual		Page
LT 25 , LT 35 LT 50 , LT 60 LT 70 , LT 90		CONTROL CABINET separate design		9-1.1
Pos.	Part N°	Part Name	Description	Quant.
1	-	Cabinet		1
2	135 523	Filter, Assembly compl. consisting of pos. 3 - 5	LG 12	2
3	135 516	Insert, Filter	AM 12	3
4	-	Screen, bottom		2
5	-	Screen, top		3
6	135 521	Fan, Cooling compl.	LS 2	1
<p>Note: Parts N° of components inside of cabinet see Wiring Diagram: „Door left and right“</p>				

<p>TYPE</p> <p>LT 25 , LT 35 LT 50 , LT 60 LT 70 , LT 90</p>	<p>Parts Manual</p> <p>VIDEO - TERMINAL COMPUTER CONTROL »PROVIT 2000«</p>	<p>Page</p> <p>9 - 1.2</p>
---	---	----------------------------

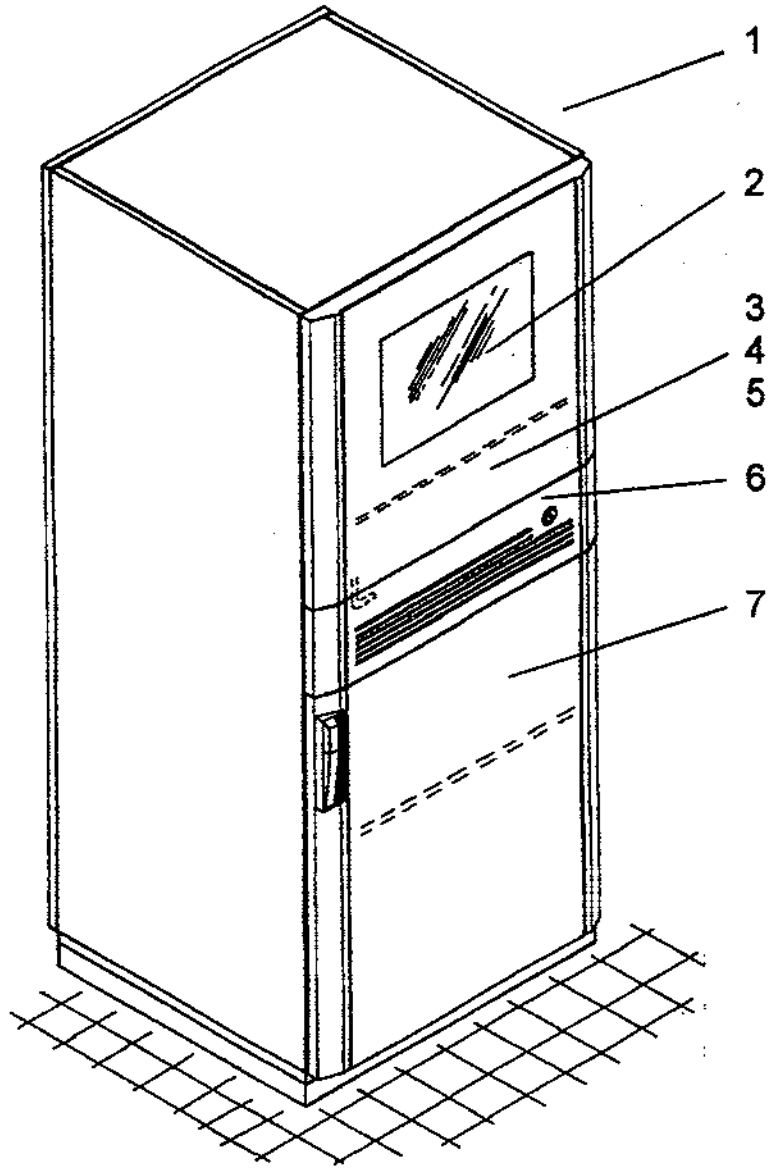

TYPE		Parts Manual		Page
LT 25 , LT 35 LT 50 , LT 60 LT 70 , LT 90		VIDEO - TERMINAL COMPUTER CONTROL »PROVIT 2000«		9 - 1.3
Pos.	Part N°	Part Name	Description	Quant.
1	136 510	PC - Cabinet 610 x 1660 x 620	PC 4610	1
2	139 422	VGA - Monitor, Color radiation-poor	14 inches	1
3	305 129-5	Floppy disk drive		1
4	139 381	Control unit with processor	5C2000.03 80486SLC-25	1
5	139 383	Centronics - Kabel 1,8 m		1 resp. 2
6	139 423	Keyboard	MF II with PS/2- connection	1
7	139 429	Printer „OKIDATA“ (Option)		1
8	139 276	Central unit (see LAVATRAC control cabinet)	E CC P 70	1

TYPE LT 25 , LT 35 LT 50 , LT 60 LT 70 , LT 90	Parts Manual LOADING SIDE in case of separate control cabinet	Page 9 - 2.0
--	---	------------------------

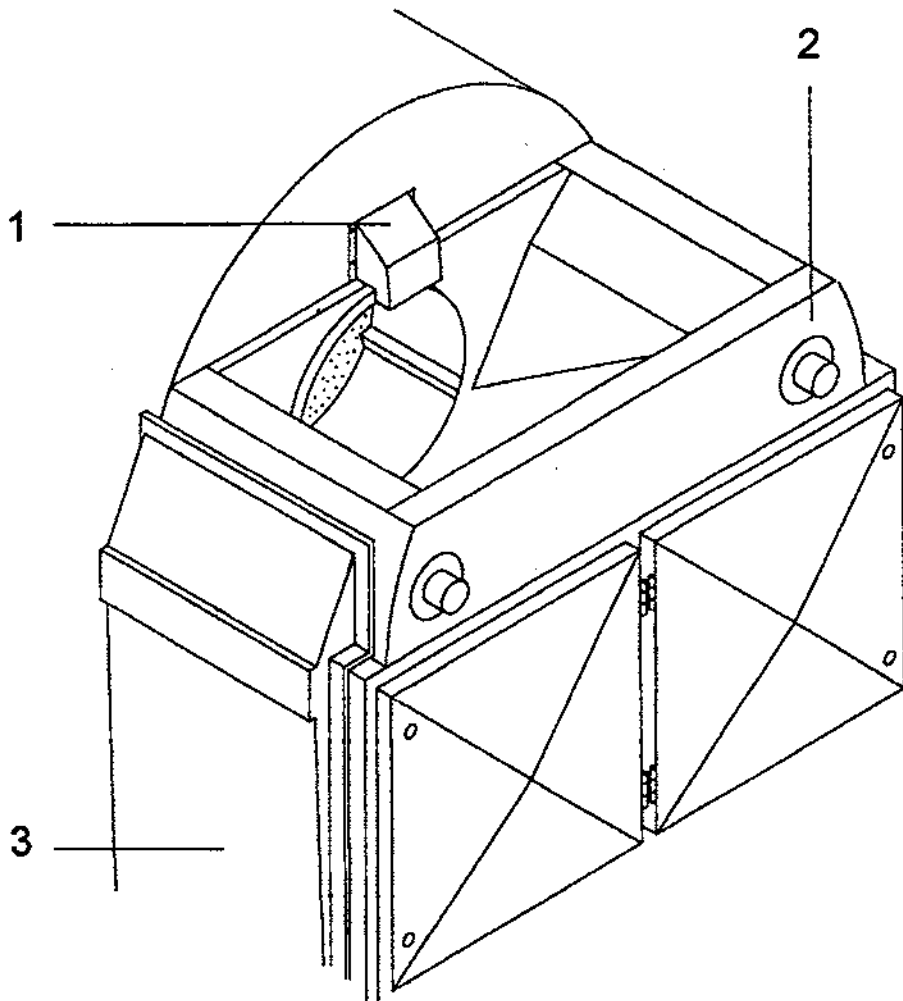

TYPE		Parts Manual		Page
LT 25 , LT 35 LT 50 , LT 60 LT 70 , LT 90		LOADING SIDE in case of separate control cabinet		9 - 2.1
Pos.	Part N°	Part Name	Description	Quant.
1	135 867	Photocell		1
2		Button, Emergency Stop consisting of:		4
	135 269	Button	RPV	
	135 274	Adapter, Bracket	BE 3	
	135 276	Block, Contact	EK 01	
	135 299	Insulator	2Z116 - 171.03.5	
	135 300	Cover	H 1 M	
	135 263	Label, Version Standard	900 1029	
	135 264	Label, Version USA	1 ak - 299	
3	340 498-2	Cover, Side		As per washer size

TYPE LT 25 , LT 35
LT 50 , LT 60
LT 70 , LT 90

Parts Manual

LOADING SIDE
with integrated control cabinet

Page
9 - 2.2

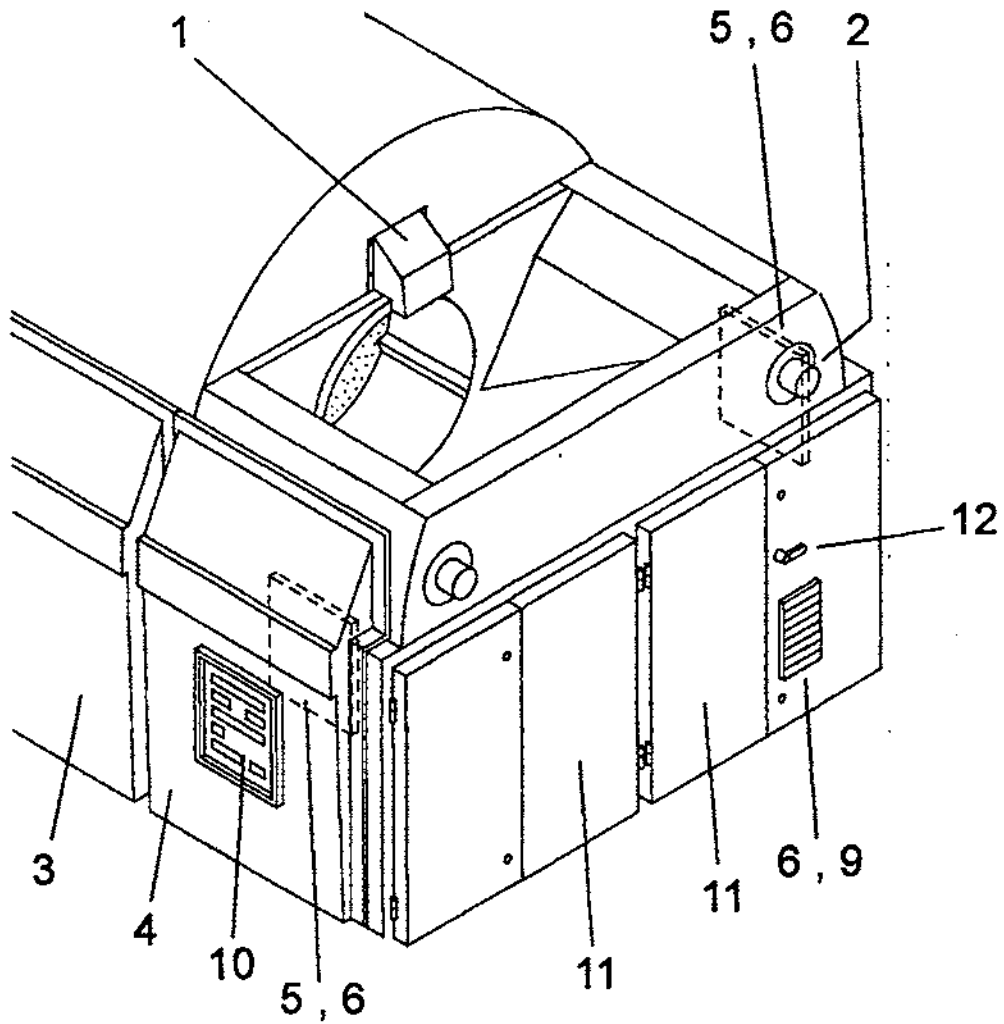

TYPE		Parts Manual		Page
LT 25 , LT 35 LT 50 , LT 60 LT 70 , LT 90		LOADING SIDE with integrated control cabinet		9 - 2.3
Pos.	Part N°	Part Name	Description	Quant.
1	135 867	Photocell		1
2	—	Button, Emergency Stop consisting of:		4
	135 269	Button	RPV	
	135 274	Adapter, Bracket	BE 3	
	135 276	Block, Contact	EK 01	
	135 299	Insulator	2Z116 - 171.03.5	
	135 300	Cover	H 1 M	
	135 263	Label, Version Standard	900 1029	
	135 264	Label, Version USA	1 ak - 299	
3	340 498-2	Cover, Side		As per washer size
4	343 319-2	Cover, Side with Cutout		1
5	135 523	Filter Set compl. consisting of pos. 6 and Screens (top and bottom)	LG 12	2
6	135 516	Insert, Filter for pos. 5 resp. 9	A M 12	3
9	135 521	Blower, Filter compl. consisting of Blower, pos. 6 and Screen (top)	LS 2 indicate voltage	1
10	—	Control and Operation Elements of Panel		
11	—	Elements of Control Cabinet	Pos. 10 to 12 see Wiring diagram	
12	—	Switch, Main		

LT 25 , LT 35
TYPE LT 50 , LT 60
LT 70 , LT 90

Parts Manual

WATER TANK

Page

9 - 3.0

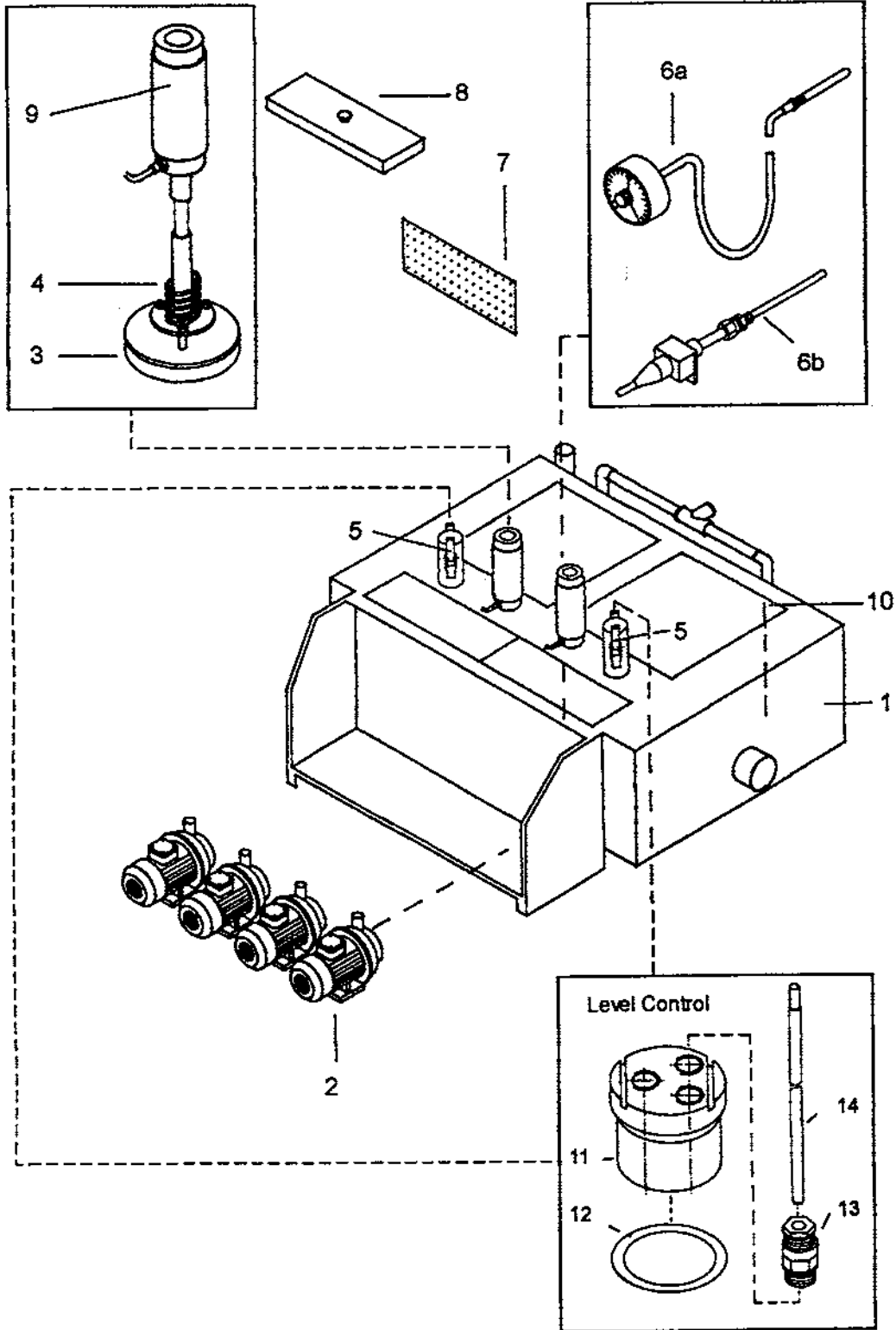

LT 25 , LT 35 TYPE LT 50 , LT 60 LT 70 , LT 90		Parts Manual WATER TANK		Page 9 - 3.1
Pos.	Part N°	Part Name	Description	Quant.
1		Tank		1
2	111 339	Pump, Water ¹⁾	KNM 251-2/1.1 indicate voltage+ Hz	3 - 5
3	340 407-4	Seal, Rubber		2
4	027 010	Spring	VD 314	2
5	121 243	Catch, Bayonet		4
6a	135 015	Thermostat	4 J 105-0 *)	1 - 2
6b	351 661-4	Thermometer, Resistance, compl. consisting of Pt 100, Joint + 7m Cable	Pt 100 *) *) see water diagram	1 - 2
7	340 759-4	Screen, Lint		2
8	340 748 4	Cover, left		1
8	340 749-4	Cover, right		1
9	111 192	Cylinder, Pneumatic	RKS 2040-0050	2
10		Valve, Reversing, compl. see page 9-3.5		1
11	353 611-4	Retainer	3 Levels	
11	353 595-4	Retainer	1 + 2 Levels	
12	028 334	O - Ring	42 x 5	2
13	137 644	Joint, Cable	Pg 7	
14	353 786-4	Sensor, compl., black	L = 260 - high	
14	353 785-4	Sensor, compl., blue	L = 325 - medium	
14	353 787-4	Sensor, compl., red	L = 445 - empty	
		¹⁾ Art.-Nr. 11 339 valid for 400 V/50 Hz, 415 V/50 Hz, 460 V/60 Hz, 480 V/ 60 Hz		

LT 25 , LT 35
TYPE LT 50 , LT 60
 LT 70 , LT 90

Parts Manual

HEATING FOR WATER TANK
 (Option)

Page

9 - 3.2

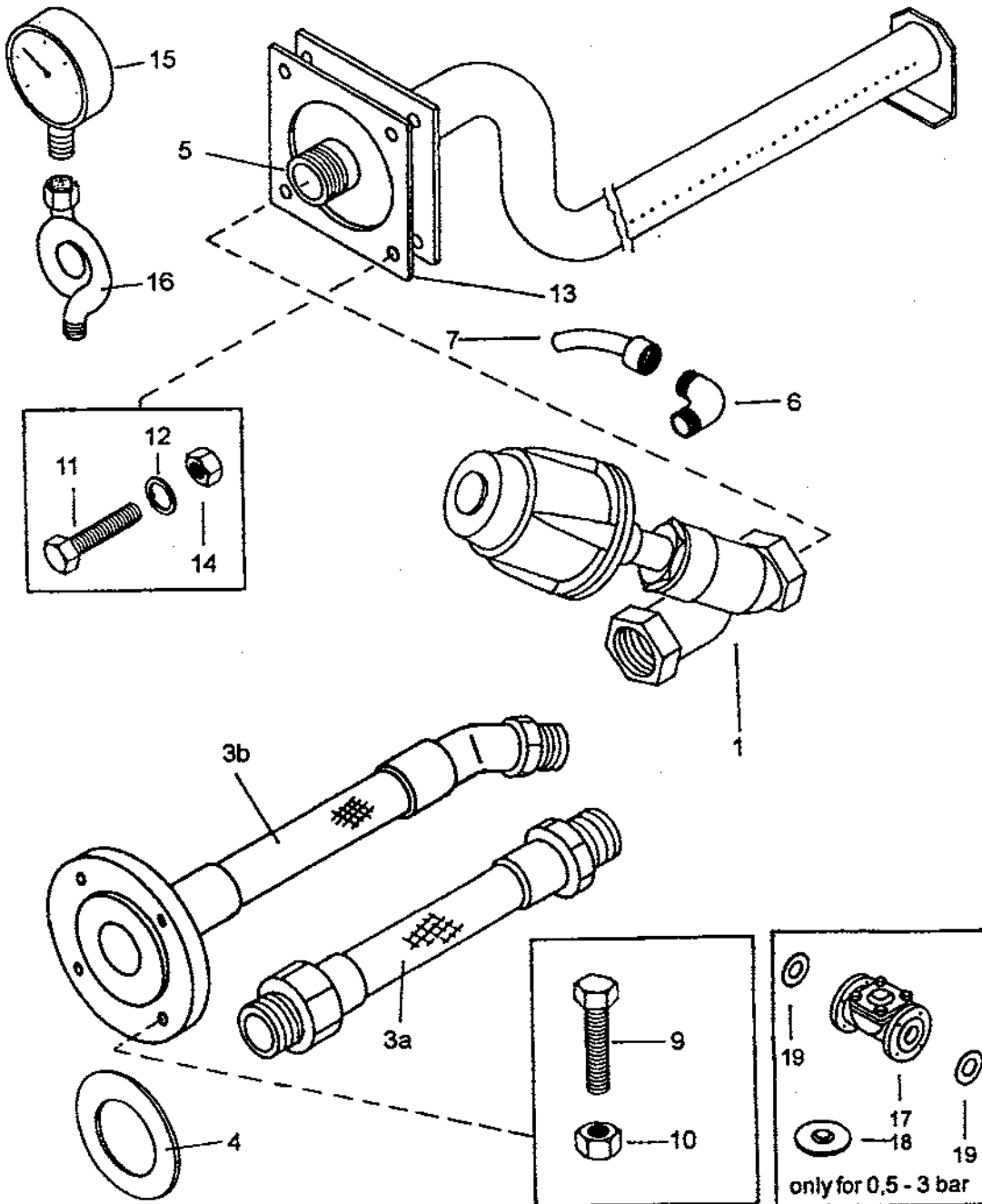

TYPE		LT 25 , LT 35 LT 50 , LT 60 LT 70 , LT 90		Parts Manual HEATING FOR WATER TANK (Option) HIGH-PRESSURE STEAM 0,5 - 3 bar (7 - 45 PSI)		Page 9 - 3.3
Pos.	Part N°	Part Name		Description	Quant.	
1	111 401	Valve, Pneumatic		514-40-D-1375-1-1	1	
3a	344 891-4	Hose, Steam, compl.		DN 40	1	
3a	355 531-4	Hose, Steam, compl.		DN 40 - SS	1	
5	351 931-4	Injector, Steam		0,5 to 3 bar	1	
6	111 077	Coupling, Elbow		G ¼ - 8/6	1	
7	006 002	Hose, Air		8 x 1 - 259.12 D	1	
11	020 243	Bolt, Hex	ISO 4017	M 8 x 16 - A2K	4	
12	020 058	Washer, Lock	DIN 128	A 8 - A2K	4	
13	340 309-4	Seal, Manifold			1	
14	020 037	Nut, Hex	ISO 4032	M 8 - 8 - A2K	4	
15	112 098	Manometer (for steam pressure)		R 100-1, 0 - 4 bar	1	
16	118 191	Tube, Water Pocket	DIN 16282	CG-G ½ AMU	1	
16	118 216	Tube, Water Pocket	DIN 16282	CG-G ½ AMU-SS	1	
17	118 006	Trap, Steam, compl.		MK 35/22	1	
18	118 057	Membrane			1	
19	028 025	Gasket	DIN 2690	20 - PN 40	2	

TYPE		LT 25 , LT 35 LT 50 , LT 60 LT 70 , LT 90		Parts Manual HEATING FOR WATER TANK (Option) HIGH-PRESSURE STEAM 3-6 resp. 6-10 bar (45-90 resp. 90-150 PSI)		Page
Pos.	Part N°	Part Name		Description	Quant.	
1	111 166	Valve, Pneumatic		514-20-D-1375-1-1	1	
3b	344 133-4	Hose, Steam, compl. with flange		DN 20	1	
3b	354 983-4	Hose, Steam, compl. with flange		DN 20 - SS	1	
4	028 025	Gasket	DIN 2690	20 - PN 40	1	
5	351 362-3	Injector, Steam		3 - 6 bar	1	
5	351 415-3	Injector, Steam		6 - 10 bar	1	
6	111 077	Coupling, Elbow		G ¼ - 8/6	1	
7	006 002	Hose, Air		8 x 1 - 259.12 D	1	
9	020 021	Bolt, Hex	ISO 4018	M 12 x 50 - A2K	4	
10	020 254	Nut, Hex	ISO 4032	M 12 - A2K	4	
11	020 243	Bolt, Hex	ISO 4017	M 8 x 16 - A2K	4	
12	020 058	Washer, Lock	DIN 128	A 8 - A2K	4	
13	340 309-4	Seal, Manifold			1	
14	020 037	Nut, Hex	ISO 4032	M 8 - 8 - A2K	4	
15	112 053	Manometer (for steam pressure)		R 100-1, 0-10 bar	1	
16	118 191	Tube, Water Pocket	DIN 16282	CG-G ½ AMU	1	
16	118 216	Tube, Water Pocket	DIN 16282	CG-G ½ AMU-SS	1	

LT 25 , LT 35
TYPE LT 50 , LT 60
LT 70 , LT 90

Parts Manual

REVERSING VALVE WATER TANK

Page
9 - 3.5

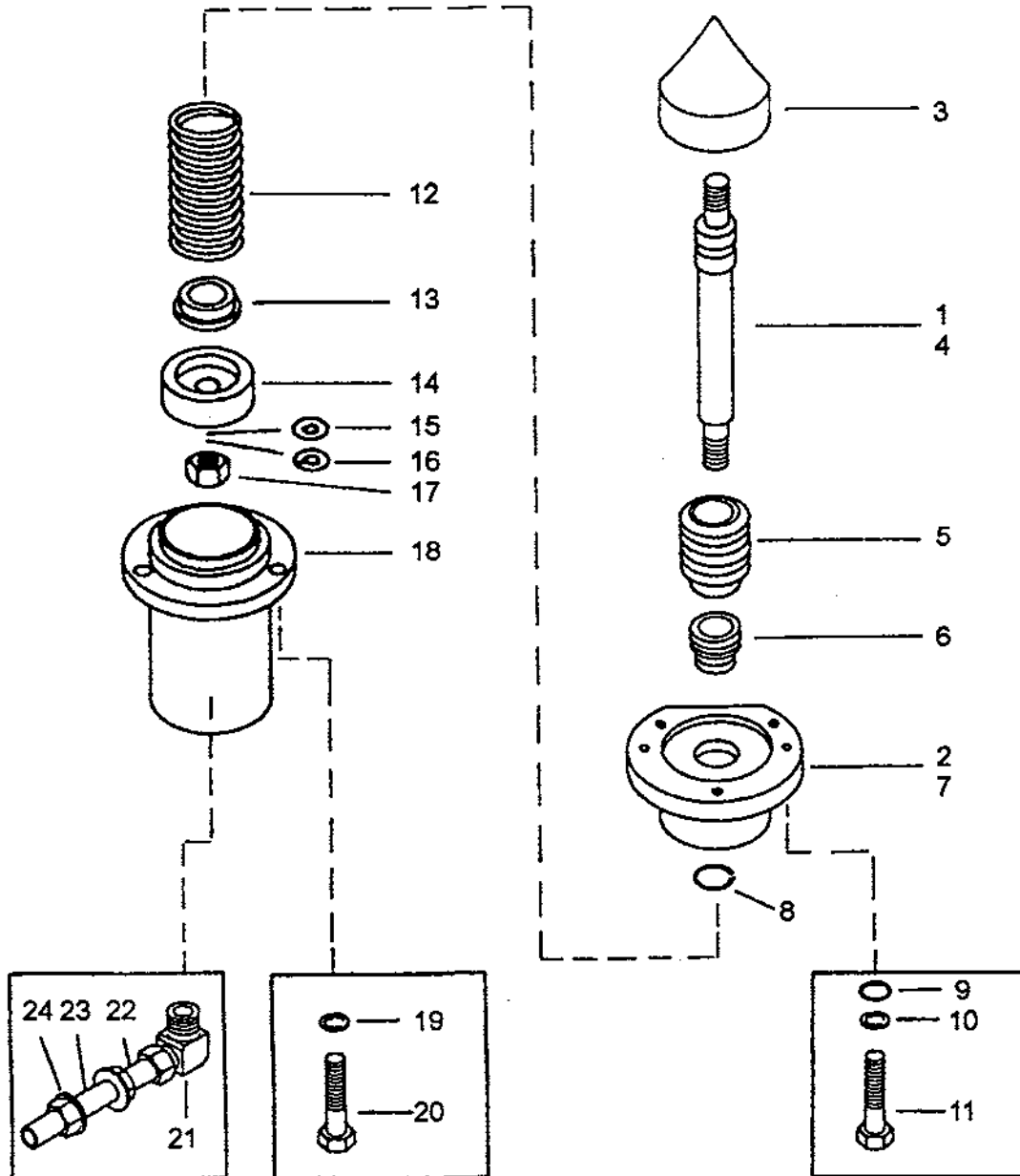

TYPE		Parts Manual		Page
LT 25 , LT 35 LT 50 , LT 60 LT 70 , LT 90		REVERSING VALVE WATER TANK		9 - 3.6
Pos.	Part N°	Part Name	Description	Quant.
	342 516-2	Valve, Reversing compl. Standard version consisting of Pos. 1 - 24 but without Pos. 4 - 8		1
	345 019-2	Valve, Reversing compl. Special version for sandy linen consisting of Pos. 3 - 24		1
1	341 653-4	Rod, Piston		1 ¹⁾
2	342 494-4	Bottom, Cylinder		1 ¹⁾
3	345 248-4	Plug, Drain		1
4	345 014-4	Rod, Piston		1 ²⁾
5	028 138	Bellow	V 6 - 302	1 ²⁾
6	345 020-4	Bush, Bearing		1 ²⁾
7	345 022-4	Bottom, Cylinder		1 ²⁾
8	025 030	Ring, Snap	DIN 7793	A 22 - 1.4310 1 ²⁾
9	020 047	Washer	DIN 125	8,4 - 140 HV - A2 2
10	020 056	Washer, Lock	DIN 128	A8 - 1.4310 2
11	020 174	Bolt, Hex	ISO 4017	M 8 x 20 - A2 - 70 2
12	027 028	Spring	VD 295	1
		1) only for standard version 2) only for special version		

TYP		Parts Manual		Blatt
LT 25 , LT 35 LT 50 , LT 60 LT 70 , LT 90		REVERSING VALVE WATER TANK		9 - 3.7
Pos.	Part N°	Part Name	Description	Quant.
13	341 654-4	Guide		1
14	028 078	Piston, Assembly with SS-Spring	TDUO 50 - 31	1
15	020 052	Washer	DIN 125 10,5 - 140 HV	1
16	020 224	Washer, Lock	DIN 128 A 10 -1.4310	1
17	020 038	Nut, Hex	ISO 4032 M 10 - 8 - gal.	1
18	341 656-4	Housing, Cylinder		1
19	020 055	Washer, Lock	DIN 128 A 6 - 1.4310	3
20	020 374	Bolt, Hex	ISO 4017 M 6 x 50 - A2 - 70	3
21	112 003	Fitting, Elbow	G ¼ - 6/8	1
22	006 002	Hose	8 x 1 x 500	1
23	111 474	Fitting, Bulk Head	Nr. 12.0531	1
24	020 507	Washer	DIN 125 A 13 -140 HV	2

LT 25 , LT 35
TYPE LT 50 , LT 60
LT 70 , LT 90

Parts Manual

DRIVE ASSEMBLY

Page

9 - 4.0

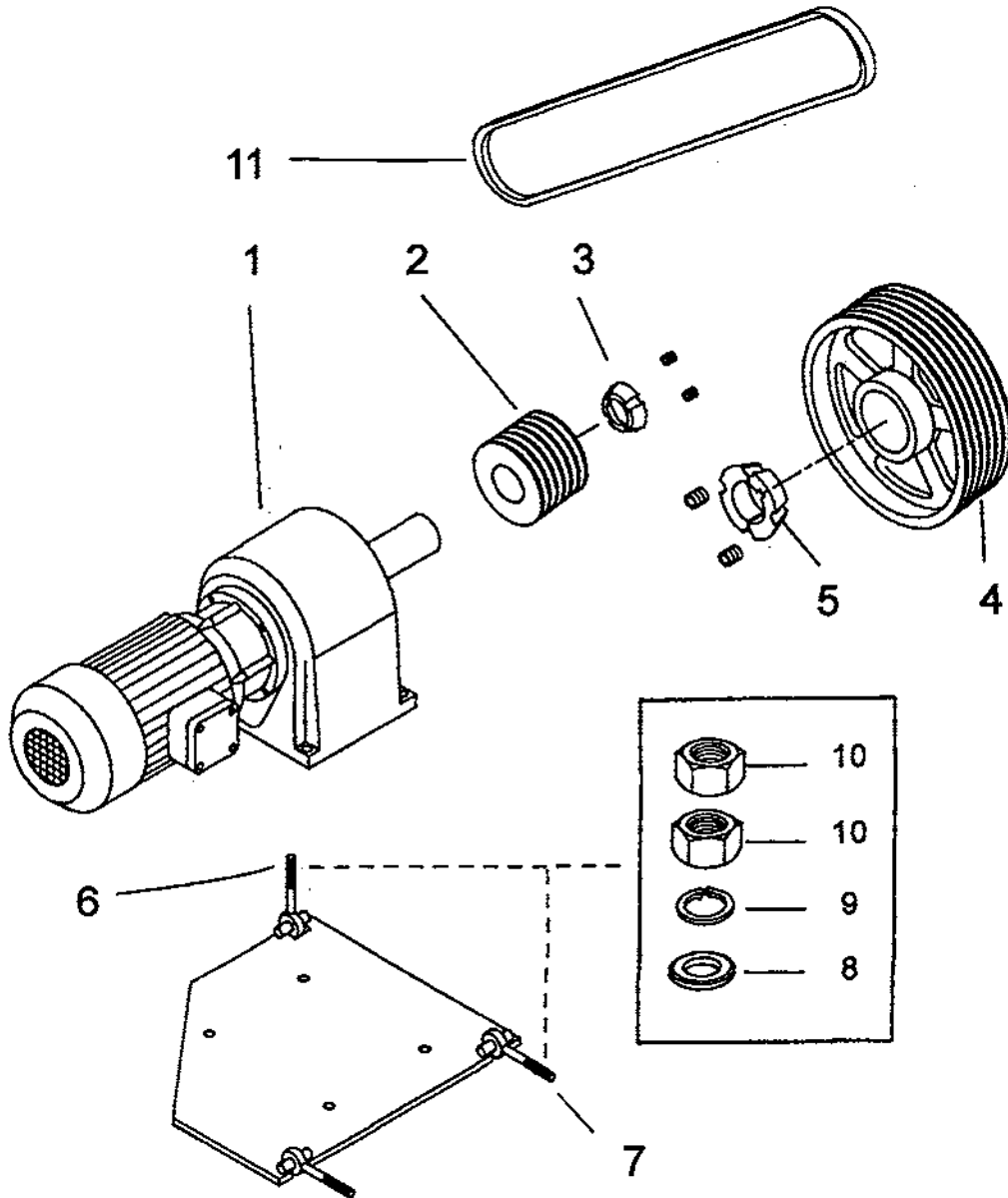

TYPE		Parts Manual		Page
LT 25 , LT 35 LT 50 , LT 60 LT 70 , LT 90		DRIVE ASSEMBLY		9 - 4.1
Pos.	Part N°	Part Name	Description	Quant.
1	*)	<p>Drive complete</p> <p>Acc. to the LAVATRAC-Type and number of compartments with :</p> <p>Gear Box 2,0 kW Gear Box 3,0 kW Gear Box 4,0 kW Gear Box 5,0 kW Gear Box 6,0 kW Gear Box 7,5 kW Gear Box 9,5 kW</p> <p><u>In case of ordering indicate:</u></p> <ul style="list-style-type: none"> ● Quantity ● Type of drive ● LAVATEC-Part N° ● Type of current ● kW ● LAVATRAC Serial N° <p><u>Note:</u></p> <p>*) The LAVATEC-Part N° is visible on the drive nameplate and on the second plate at the LAVATRAC frame.</p> <p>Drives are lacquered:</p> <ul style="list-style-type: none"> ● gray = old generation ● blue = new generation (from 2002-08) 	<p>G 180 G 200 G 200 G 225 G 250 G 250 G 250</p>	

TYPE		Parts Manual		Page
LT 25 , LT 35 LT 50 , LT 60 LT 70 , LT 90		DRIVE ASSEMBLY		9 - 4.2
Pos.	Part N°	Part Name	Description	Quant.
<u>Drive 2 kW, 400 V / 50 Hz</u>				
2	103 366	Pulley	SPB 190 x 4	2
3	103 106	Hub, Tension	TL 2517 - 45	2
<u>Drive 2 kW, 480 V / 60 Hz</u>				
2	103 420	Pulley	SPB 160 x 4	2
3	103 106	Hub, Tension	TL 2517 - 45	2
<u>Drives 3 + 4 kW, 400 V / 50 Hz</u>				
2	103 094	Pulley	SPB 190 x 6	*)
3	103 397	Hub, Tension	TL 3020 - 55	*)
<u>Drives 3 + 4 kW, 480 V / 60 Hz</u>				
2	103 059	Pulley	SPB 160 x 6	*)
3	103 397	Hub, Tension	TL 3020 - 55	*)
<u>Drive 5 kW, 400 V / 50 Hz</u>				
2	103 094	Pulley	SPB 190 x 6	4
3	103 323	Hub, Tension	TL 3020 - 60	4
<u>Drive 5 kW, 480 V / 60 Hz</u>				
2	103 059	Pulley	SPB 160 x 6	4
3	103 323	Hub, Tension	TL 3020 - 60	4
<u>Drive 6 kW, 400 V / 50 Hz</u>				
2	103 563	Pulley	SPB 190 x 8	4
3	103 567	Hub, Tension	TL 3030 - 65	4
<u>Drive 6 kW, 480 V / 60 Hz</u>				
2	103 564	Pulley	SPB 160 x 8	4
3	103 362	Hub, Tension	TL 3030 - 65	4
*) Quantities as per N° of drives				

TYPE		Parts Manual		Page
LT 25 , LT 35 LT 50 , LT 60 LT 70 , LT 90		DRIVE ASSEMBLY		9 - 4.3
Pos.	Part N°	Part Name	Description	Quant.
		<u>Drive 7,5 kW, 400 V / 50 Hz</u>		
2	361 838-4	Pulley	SPB 190 x 10	4
		<u>Drive 7,5 kW, 480 V / 60 Hz</u> <u>Drive 7,5 kW, 230 V / 60 Hz</u>		
2	361 837-4	Pulley	SPB 160 x 10	4
		<u>Drive 9,5 kW, 400 V / 50 Hz</u>		
2	357 147-4	Pulley	SPB 190 x 12	4
		<u>Drive 9,5 kW, 480 V / 60 Hz</u>		
2	357 146-4	Pulley	SPB 160 x 12	4
		<u>Drive 2 x 2 kW</u>		
4	103 365	Pulley	SPB 450 x 2	4
5	103 362	Hub, Tension	TL 3020 - 65	4
		<u>Drives 2 x 3 kW und 2 x 4 kW</u>		
4	103 137	Pulley	SPB 450 x 3	4
5	103 282	Hub, Tension	TL 3535 - 65	4
		<u>Drives 4 x 3 kW</u> <u>4 x 4 kW</u> <u>4 x 5 kW</u>		
4	103 060	Pulley	SPB 450 x 6	4
5	103 227	Hub, Tension	TL 4040 - 65	4
		<u>Drive 6 kW</u>		
4	103 226	Pulley	SPB 450 x 8	4
5	103 227	Hub, Tension	TL 4040 - 65	4

TYPE		Parts Manual		Page
LT 25 , LT 35 LT 50 , LT 60 LT 70 , LT 90		DRIVE ASSEMBLY		9 - 4.4
Pos.	Part N°	Part Name	Description	Quant.
		<u>Drive 7,5 kW</u>		
4	103 421	Pulley	SPB 450 x 10	4
5	103 227	Hub, Tension	TL 4040 - 65	4
		<u>Drive 9,5 kW</u>		
4	103 516	Pulley	SPB 450 x 12	4
5	103 518	Hub, Tension	TL 4545 - 80	4
6	020 514	Bolt, Eye	DIN 444 - L - A M 20 x 140	8
7	020 515	Bolt, Eye	DIN 444 - L - A M 20 x 220	4
8	020 154	Washer	DIN 125 - 21	12
9	020 260	Washer, Lock	DIN 128 - A 20	12
10	020 255	Nut, Hex	ISO 4032 - M 20 - 8	24
11	103 260	V-Belt	DIN 7753 - SPB 2650	1)
11	103 392	V-Belt	DIN 7753 - SPB 2600	2)
		LT 25 : up to 6 Compartments		2 x 4
		LT 25 : 7 - 13 Compartments		2 x 6
		LT 35 : 5 - 9 Compartments		2 x 6
11	103 233	V-Belt	DIN 7753 - SPB 2840	1)
11	103 232	V-Belt	DIN 7753 - SPB 2800	2)
		LT 50 : 5 and 6 Compartments		2 x 6
		LT 60 : 5 Compartments		2 x 6
		1) for drives 50 Hz		
		2) for drives 60 Hz		

TYPE		Parts Manual		Page
LT 25 , LT 35 LT 50 , LT 60 LT 70 , LT 90		DRIVE ASSEMBLY		9 - 4.5
Pos.	Part N°	Part Name	Description	Quant.
11	103 134	V-Belt DIN 7753 - LT 25 : 14 - 20 Compartments LT 35 : 10 - 18 Compartments LT 50 : 7 - 13 Compartments LT 60 : 6 - 10 Compartments LT 70 : 7 - 9 Compartments LT 90 : 5 - 9 Compartments	SPB 2000	1) 2) 4 x 6 4 x 6 4 x 6 4 x 6 4 x 6 4 x 6
11	103 228	V-Belt DIN 7753 - LT 35 : 19 u. 20 Compartments LT 50 : 14 - 16 Compartments LT 60 : 11 - 16 Compartments LT 70 : 10 u. 11 Compartments	XPB 2000 (Quad-Power)	1) 2) 4 x 6 4 x 6 4 x 8 4 x 8
11	103 313	V-Belt DIN 7753 - LT 50 : 17 - 20 Compartments LT 60 : 17 - 20 Compartments LT 70 : 12 + 13 Compartments LT 70 : 14 - 16 Compartments LT 70 : 17 - 20 Compartments LT 90 : 10 + 11 Compartments LT 90 : 12 - 14 Compartments LT 90 : 15 - 17 Compartments	XPB 2120 (Quad-Power)	1) 2) 4 x 8 4 x 10 4 x 10 4 x 10 4 x 12 4 x 8 4 x 10 4 x 12
		1) for drives 50 Hz		
		2) for drives 60 Hz		

LT 25 , LT 35
TYPE LT 50 , LT 60
LT 70 , LT 90

Parts Manual

DRUM WHEELS ASSEMBLY

Page

9 - 5.0

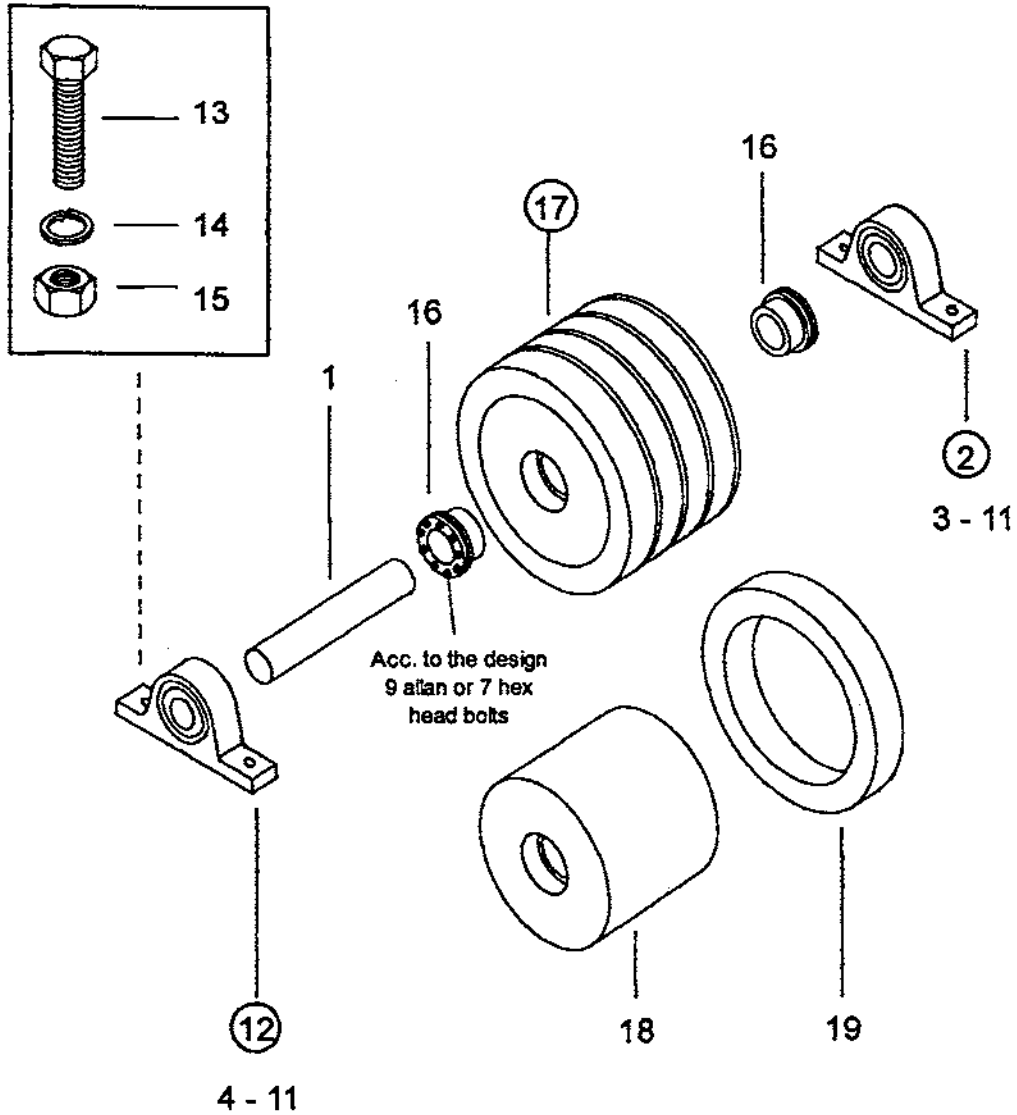

Note: Parts list for drum wheels assembly with 9,5 kW see pages 9-5.4 to 9.5.6

LT 25 , LT 35
TYPE LT 50 , LT 60
LT 70 , LT 90

Parts Manual

DRUM WHEELS ASSEMBLY
Plummer Block Assembly

Page
9 - 5.1

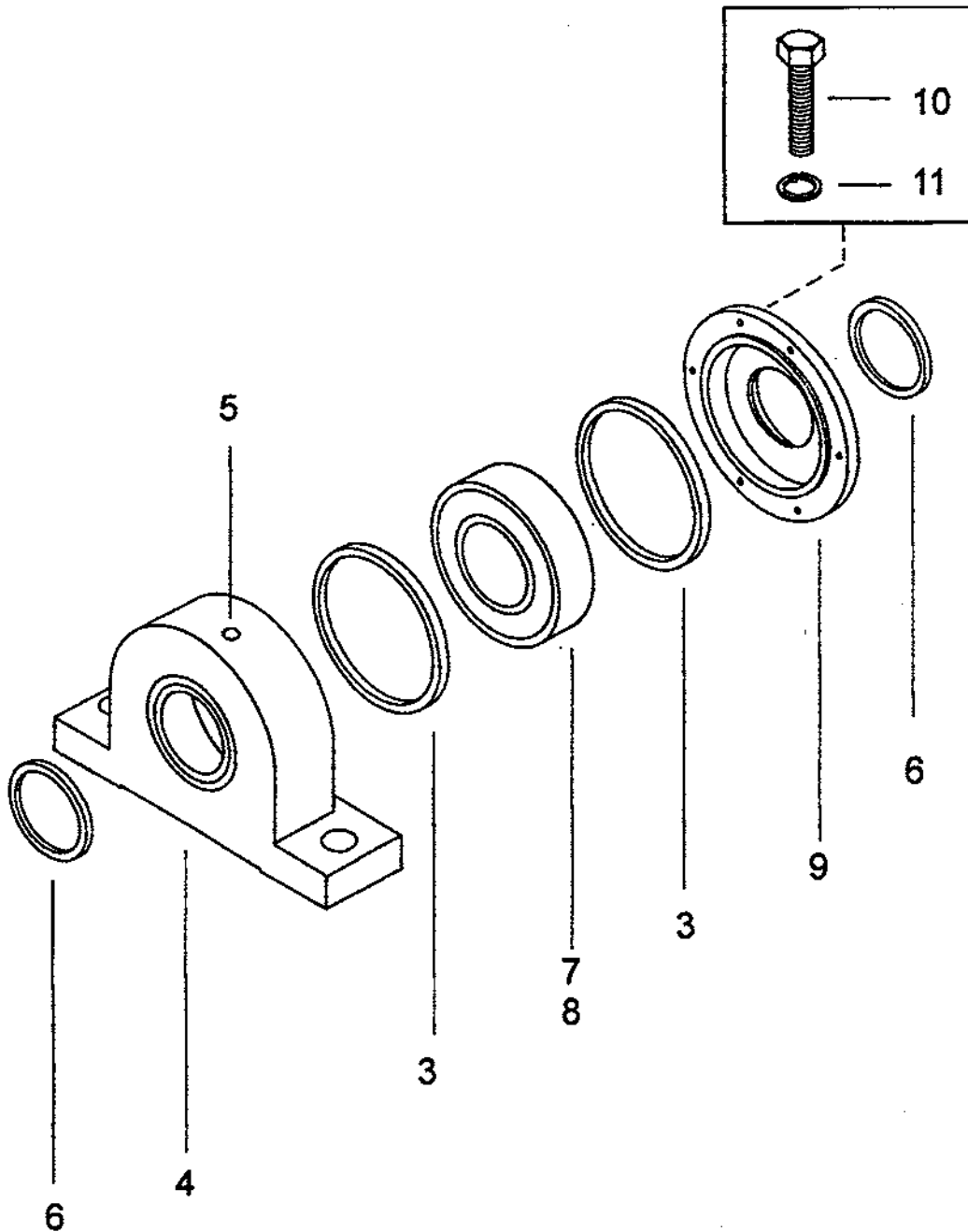

Note: Parts list for drum wheels assembly with 9,5 kW see pages 9-5.4 to 9.5.6

LT 25 , LT 35 TYPE LT 50 , LT 60 LT 70 , LT 90		Parts Manual DRUM WHEELS ASSEMBLY In case of drive with 9,5 kW see pages 9-5.4 to 9-5.6		Page 9 - 5.2	
Pos.	Part N°	Part Name	Description	Quant.	
1	345 636-4	Shaft	440 mm long	4 ¹⁾	
1	340 259-4	Shaft	540 mm long	4 ¹⁾	
1	340 258-4	Shaft	640 mm long	4 ¹⁾	
1	343 633-4	Shaft	680 mm long	4 ¹⁾	
2	349 014-4	Plummer Block compl. consisting of pos. 3 - 11	Fixed bearing	4	
3	100 208	Ring, Distance	FR 130 / 8	8	
4	350-894-2	Housing, Plummer Block		4	
5	32025	Plug	1/8" - PVC	4	
6	028 300	V-Ring (Seal)	VA - 0065	8	
7	100 176	Bearing, Spherical Roller	22215-ESK- TVPB.C3	4	
8	100 210	Sleeve, Adapter, compl.	H 215	4	
9	350 895-3	Cover, Plummer Block		4	
10	020 015	Bolt, Hex	ISO 4017	M 8 x 20 - 8.8	24
11	020 058	Washer, Lock	DIN 128	A 8	24
12	349 080-4	Plummer Block compl. consisting of pos. 4 - 11	Movable bearing	4 ²⁾	
13	020 341	Bolt, Hex	ISO 4017	M 8 x 80 - 8.8	16
14	020 260	Washer, Lock	DIN 128	A 20	16
15	020 255	Nut, Hex	ISO 4032	M 20 - 8	16
<hr/> ¹⁾ and ²⁾ see page Blatt 9-5.3					

TYPE		LT 25 , LT 35 LT 50 , LT 60 LT 70 , LT 90		Parts Manual	Page
				DRUM WHEELS ASSEMBLY	9 - 5.3
				In case of drive with 9,5 kW see pages 9-5.4 to 9-5.6	
Pos.	Part N°	Part Name	Description	Quant.	
16	103 068	Hub, Tension TAS	S 3006 / 65 / 84	8	
17	346 191-4	Wheel compl. consisting of Pos. 18 + 19	with 2 tires	4 ¹⁾	
17	346 192-4	Wheel compl. consisting of Pos. 18 + 19	with 4 tires	4 ¹⁾	
18	340 273-4	Hub	for 2 tires	4 ¹⁾	
18	340 272-4	Hub	for 4 tires	4 ¹⁾	
19	348 455-4	Tire, Polyurethane	407 - 305 - 75	8 - 16	
		¹⁾ as per drum length ²⁾ Pos. 12 like pos. 2 but without ring pos. 3			

TYPES
≥

LT 50 x 17 CT
LT 70 x 17 BT
LT 90 x 15 BT

Parts Manual

DRUM WHEELS ASSEMBLY

Page

9 - 5.4

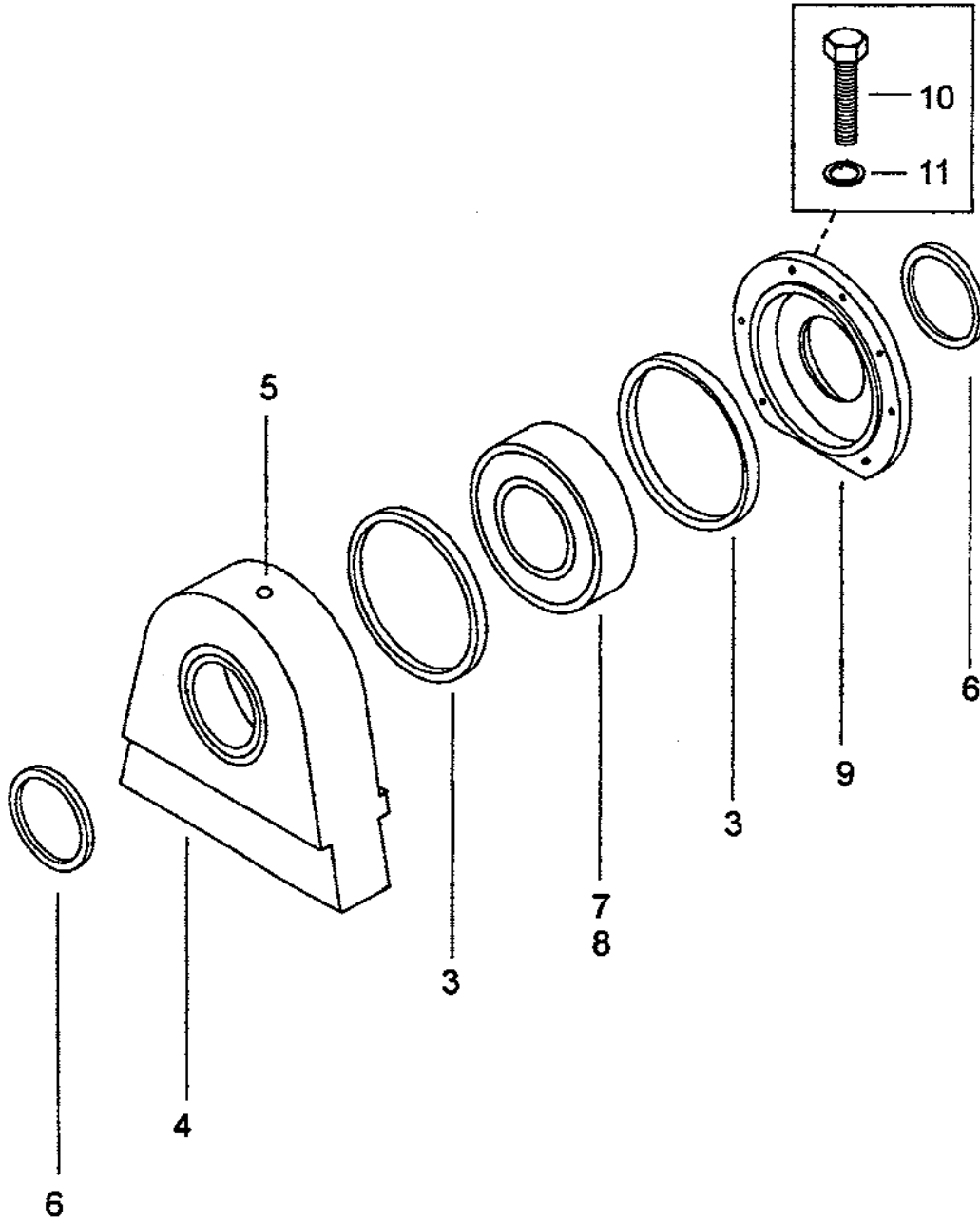

Note: Design only for drive with 9,5 kW

TYPES ≥		LT 50 x 17 CT LT 70 x 17 BT LT 90 x 15 BT	Parts Manual	DRUM WHEELS ASSEMBLY Parts list only for drive with 9,5 kW	Page 9 - 5.5
Pos.	Part N°	Part Name	Description	Quant.	
1	357 145-4	Shaft		4	
2	357 068-4	Plummer Block compl. consisting of pos. 3 - 11	Fixed bearing	4	
3	100 291	Ring, Distance	FR 160 / 12,5- FAG	8	
4	357 069-3	Housing, Plummer Block		4	
5	32025	Plug	1/8" - PVC	4	
6	028 427	V-Ring (Seal)	VA - 0080	8	
7	100 289	Bearing, Spherical Roller	22218-ESK- TVPB.C3	4	
8	100 290	Sleeve, Adapter, compl.	H 318	4	
9	357 070-4	Cover, Plummer Block		4	
10	020 174	Bolt, Hex	ISO 4017	M 8 x 20 - 8.8	14
11	020 056	Washer, Lock	DIN 128	A 8	14
12	357 067-3	Plummer Block compl. consisting of pos. 4 - 11	Movable bearing	4 ¹⁾	
		¹⁾ Pos. 12 like pos. 2 but without ring pos. 3			

TYPES ≥		LT 50 x 17 CT LT 70 x 17 BT LT 90 x 15 BT	Parts Manual	DRUM WHEELS ASSEMBLY Parts list only for drive with 9,5 kW	Page 9 - 5.6
Pos.	Part N°	Part Name	Description	Quant.	
16	103 514	Hub, Tension TAS	S 3006 / 080 / 100	8	
17	357 071-4	Wheel compl. consisting of Pos. 18 + 19	with 1 tire	4 ¹⁾	
17	357 072-4	Wheel compl. consisting of Pos. 18 + 19	with 4 tires	4 ¹⁾	
18	357 074-4	Hub	for 1 tire	4 ¹⁾	
18	340 073-4	Hub	for 4 tires	4 ¹⁾	
19	348 455-4	Tire, Polyurethane	407 - 305 - 75	20	
		<hr/> ¹⁾ as per drum length			

LT 25 , LT 35
 TYPE LT 50 , LT 60
 LT 70 , LT 90

Parts List

CENTRAL SUPPORT
 (19 Compartments and up)

Page
 9 - 6.0

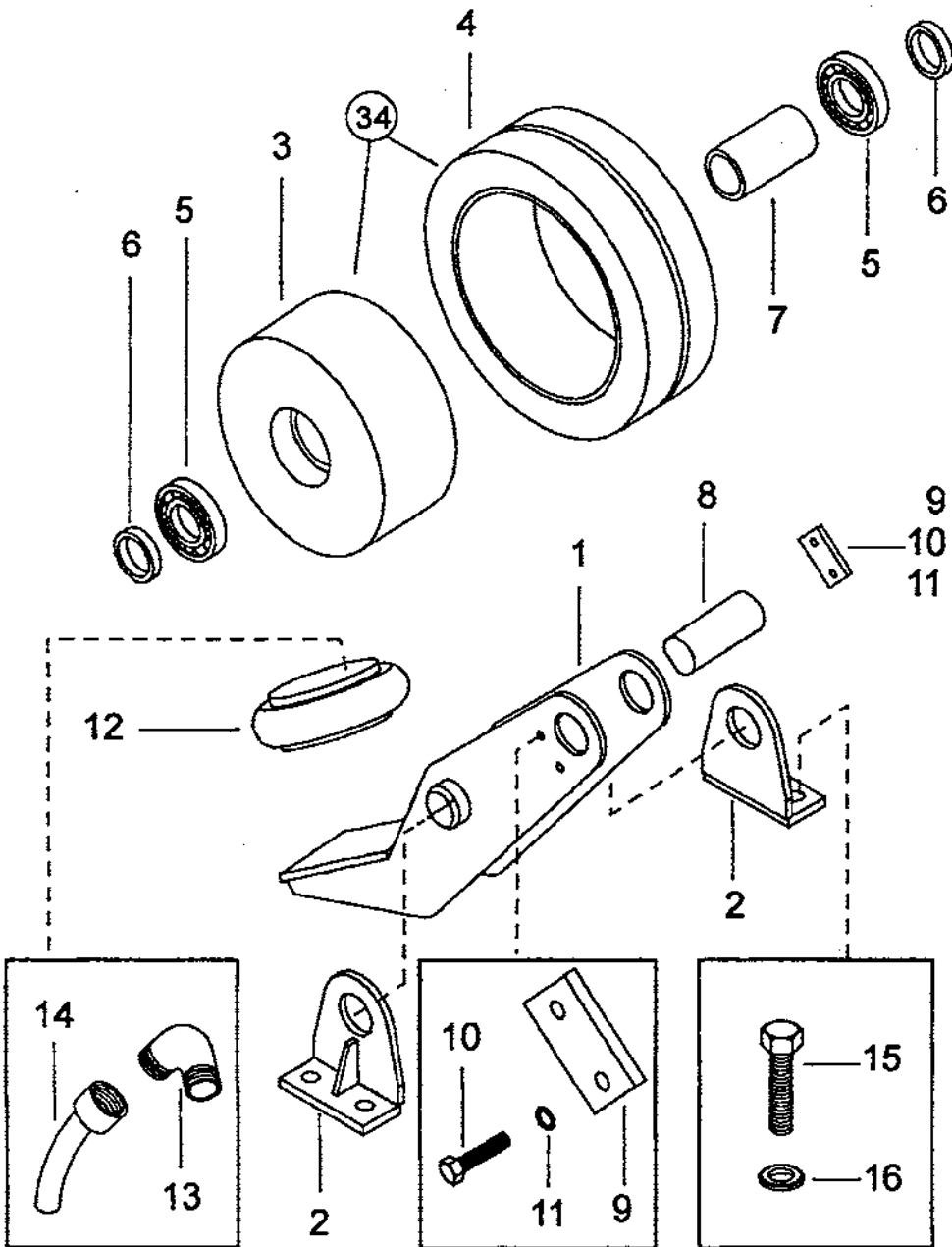

TYPE		Parts List		Page
LT 25 , LT 35 LT 50 , LT 60 LT 70 , LT 90		CENTRAL SUPPORT (19 Compartments and up)		9 - 6.1
Pos.	Part N°	Part Name	Description	Quant.
1	341 616-3	Frame		2
2	341 625-4	Support		4
3	341 535-4	Hub		2
4	348 455-4	Tire, Polyurethane	407 - 305 - 75	2
5	100 095	Bearing, Ball	6213 2 RS - C3	4
6	341 614-4	Spacer		4
7	341 615-4	Spacer		2
8	341 621-4	Shaft		2
9	341 620-4	Holder		4
10	020 174	Bolt, Hex	ISO 4017 - M 8 x 20 - A 2 - 70	8
11	020 058	Washer, Lock	DIN 128 - A 8	8
12	111 653	Bellow, Air		2
13	111 077	Coupling Elbow	G ¼ - 8/6	2
14	006 002	Hose, Air	8 x 1 - 259,12 D	
15	020 238	Bolt, Hex	ISO 4017 - M 16 x 55-8.8-A2K	8
16	020 054	Washer	DIN 125 - 17 - 140 HV	8
34	346 193-4	Wheel compl. consisting of pos. 3 + 4		2

TYPE

LT 25 , LT 35
LT 50 , LT 60
LT 70 , LT 90

Parts List

DRUM AXIAL BEARING

Page

9 - 7.0

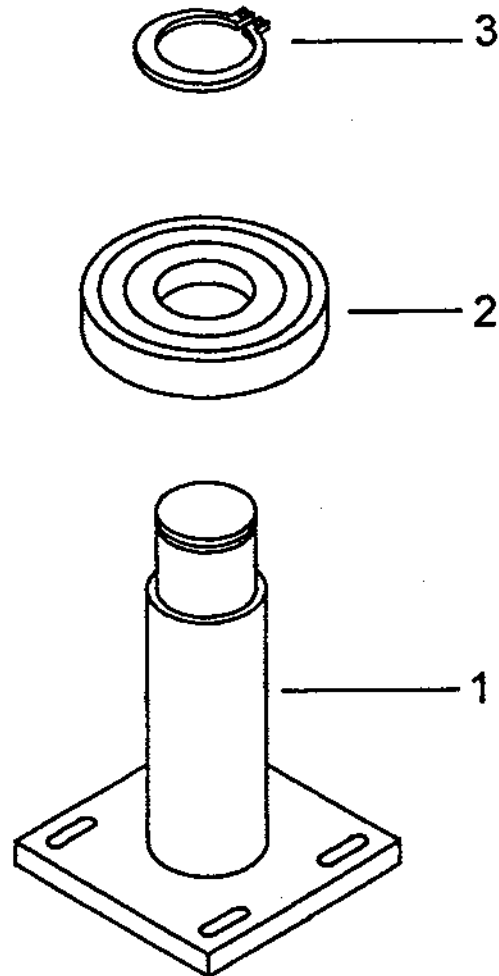

TYPE		Parts List		Page
LT 25 , LT 35 LT 50 , LT 60 LT 70 , LT 90		DRUM AXIAL BEARING		9 - 7.1
Pos.	Part N°	Part Name	Description	Quant.
1	341 395-4	Bracket, Bearing	LR 5307 BPPU	2
2	100 049	Follower, Cam		2
3	025 015	Ring, Snap	DIN 471 35 x 1,5	2

	LT 25 , LT 35	Parts List	Page
TYPE	LT 50 , LT 60	DRUM LIMIT SWITCH	9 - 8.0
	LT 70 , LT 90		

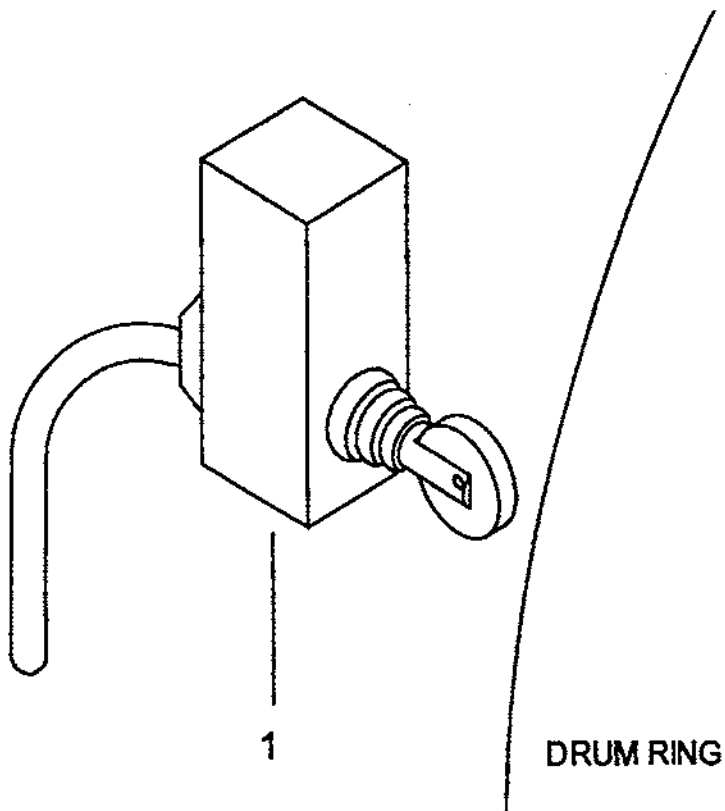

TYPE		Parts List		Page
LT 25 , LT 35 LT 50 , LT 60 LT 70 , LT 90		DRUM LIMIT SWITCH		9 - 8.1
Pos.	Part N°	Part Name	Description	Quant.
1	135 458	Switch, Limit	ID 501 - VRL	2
		<p>NOTE</p> <p>Valid from serial numbers: 25 001 = LT 25 35 020 = LT 35 50 036 = LT 50</p>		
1	135 454	Switch, Limit with roller tappet head	ATO-11-S-IA/RS	2

	LT 25 , LT 35	Parts List	Page
TYPE	LT 50 , LT 60	REVERSING CONTROL	9 - 9:0
	LT 70 , LT 90		

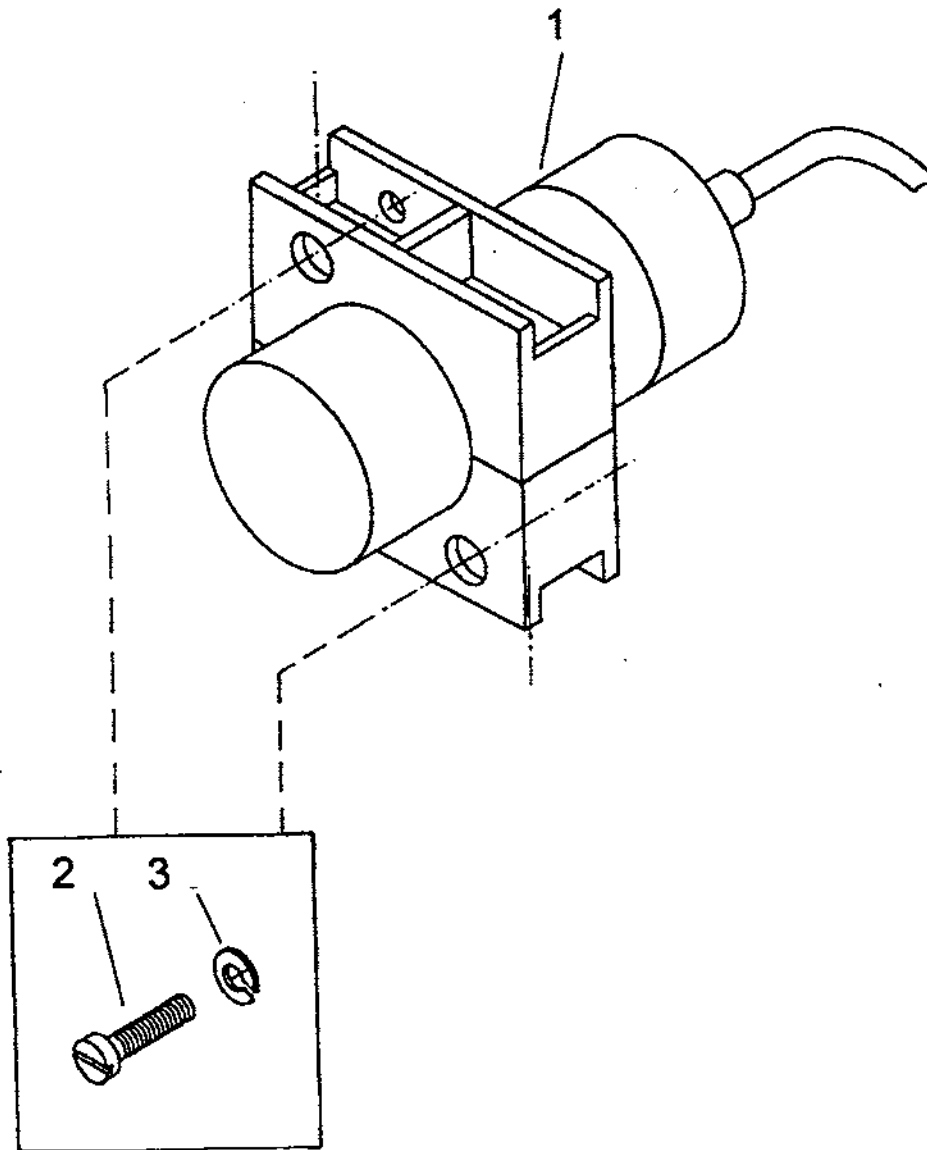

TYPE		Parts List		Page	
LT 25 , LT 35 LT 50 , LT 60 LT 70 , LT 90		REVERSING CONTROL		9 - 9.1	
Pos.	Part N°	Part Name		Description	Quant.
1	135 490	Switch, Proximity, inductive, compl.		IB - 0004 IB - 2020 - ABOA	5
		Consisting of: Switch with 2 m PVC-Cable 2 x 0,5 mm ² , Clamp, Bolts and Nuts			
2	020 302	Screw, Pan Head	DIN 84	M 5 x 12	
3	020 262	Washer, Lock	DIN 128	A 5	
		For serial N°	35 177 50 353		
		and from serial N°	25 036 35 181 50 377		
1	136 806	Switch, Proximity, inductive, compl.		IB - 5096	5
		Consisting of: Switch with 2 m PVC-Cable 2 x 0,5 mm ² , Clamp, Bolts and Nuts			
		NOTE: Parts 135490 and 136806 are not interchangeable			

TYPE LT 25 , LT 35
LT 50 , LT 60
LT 70 , LT 90

Parts Manual

TEMPERATURE CONTROL,
LIQUOR-TANK HEATING
Double-drum area

Page
9 - 10.0

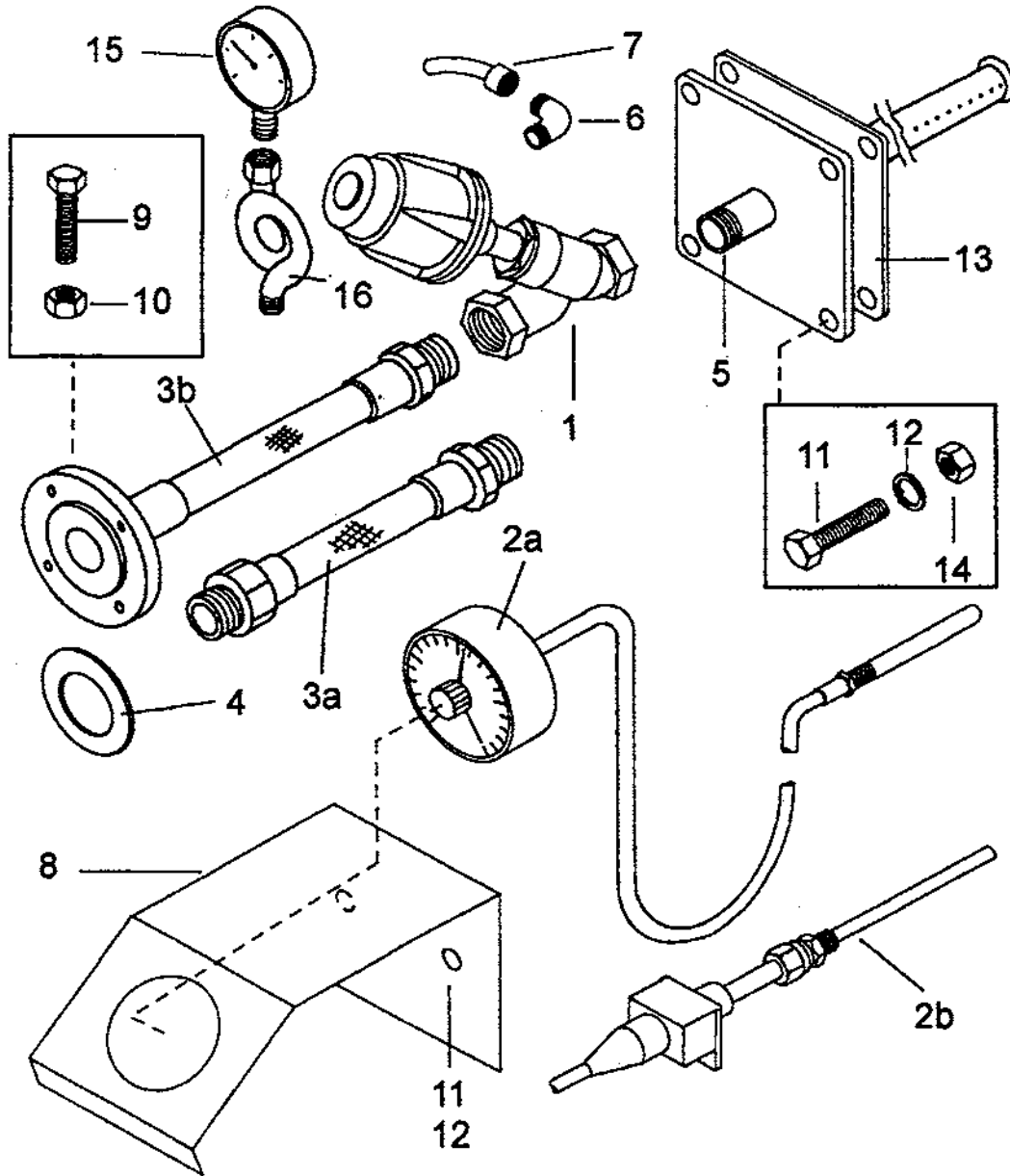

TYPE		Parts Manual		Page
LT 25 , LT 35 LT 50 , LT 60 LT 70 , LT 90		TEMPERATURE CONTROL, LIQUOR- TANK HEATING (Double-drum area) for low-pressure steam 0,5 - 3 bar (7 - 45 PSI)		9-10.1
Pos.	Part N°	Part Name	Description	Quant.
1	111 401	Valve, Pneumatic	514-40-D-1375-1-1	1
2a	135 010	Thermostat, w. 1 Switch	4 S 105 - 0	1 *)
2a	135015	Thermostat, w. 2 Switch	4 J 105 - 0	1 *)
2b	305 123-5	Thermometer, Resistance, compl.	PT 100	1 *)
3a	344 891-4	Hose, Steam, complete	DN 40	1
3a	355 531-4	Hose, Steam, complete	DN 40 - SS	1
5	351 909-4	Injector, Steam	0,5 to 3 bar	1
6	111 077	Coupling, Elbow	G ¼ - 8/6	1
7	006 002	Hose, Air	8 x 1 - 259.12 D	1
8	340 247-4	Bracket, Thermometer		1
11	020 243	Bolt, Hex	ISO 4017 M 8 x 16 A2K	1
12	020 058	Washer, Lock	DIN 128 A 8 - A2K	1
13	340 309-4	Seal, Manifold		1
14	020 037	Nut, Hex	ISO 4032 M 8 - 8 - A2K	1
15	112 098	Manometer (for steam pressure)	R 100-1, 0-4 bar	1
16	118 191	Tube, Water Pocket	DIN 16282 CG-G ½ AMU	1
16	118 216	Tube, Water Pocket	DIN 16282 CG-G ½ AMU-SS	1
*) For use see water flow diagram				

TYPE		Parts Manual		Page
LT 25 , LT 35 LT 50 , LT 60 LT 70 , LT 90		TEMPERATURE CONTROL, LIQUOR-TANK HEATING (Double-drum area) for high-pressure steam 3-6 and 6-10 bar (45-90 and 90-150 PSI)		9-10.2
Pos.	Part N°	Part Name	Description	Quant.
1	111 166	Valve, Pneumatic	514-20-D-1375-1-3	1
2a	135 010	Thermostat, w. 1 Switch	4 S 105 - 0	1 *)
2a	135015	Thermostat, w. 2 Switch	4 J 105 - 0	1 *)
2b	305 123-5	Thermometer, Resistance, compl	PT 100	1 *)
3b	344 133-4	Hose, Steam, compl. incl. FL	DN 20	1
3b	355 983-4	Hose, Steam, compl. incl. FL	DN 20 - SS	1
4	028 025	Gasket DIN 2690	20 - PN 40	1
5	350 702-4	Injector, Steam	3 to 6 bar	1
5	350 645-4	Injector, Steam	6 to 10 bar	1
6	111 077	Coupling, Elbow	G ¼ - 8/6	1
7	006 002	Hose, Air	8 x 1 - 259.12 D	1
8	340 247-4	Bracket, Thermometer		1
9	020 021	Bolt, Hex ISO 4018	M 12 x 50 - A2K	1
10	020 254	Nut, Hex ISO 4032	M 12 - A2K	1
11	020 243	Bolt, Hex ISO 4017	M 8 x 16 A2K	1
12	020 058	Washer, Lock DIN 128	A 8 - A2K	1
13	340 309-4	Seal, Manifold		1
14	020 037	Nut, Hex ISO 4032	M 8 - 8 - A2K	1
15	112 053	Manometer (for steam pressure)	R 100-1, 0-10 bar	1
16	118 191	Tube, Water Pocket DIN 16282	CG-G ½ A/MU	1
16	118 216	Tube, Water Pocket DIN 16282	CG-G ½ A/MU-SS	1
*) For use see water flow diagram				

LT 25 , LT 35
TYPE LT 50 , LT 60
LT 70 , LT 90

Parts Manual

PARTS FOR STEAM LINE

Page
9 - 10.3

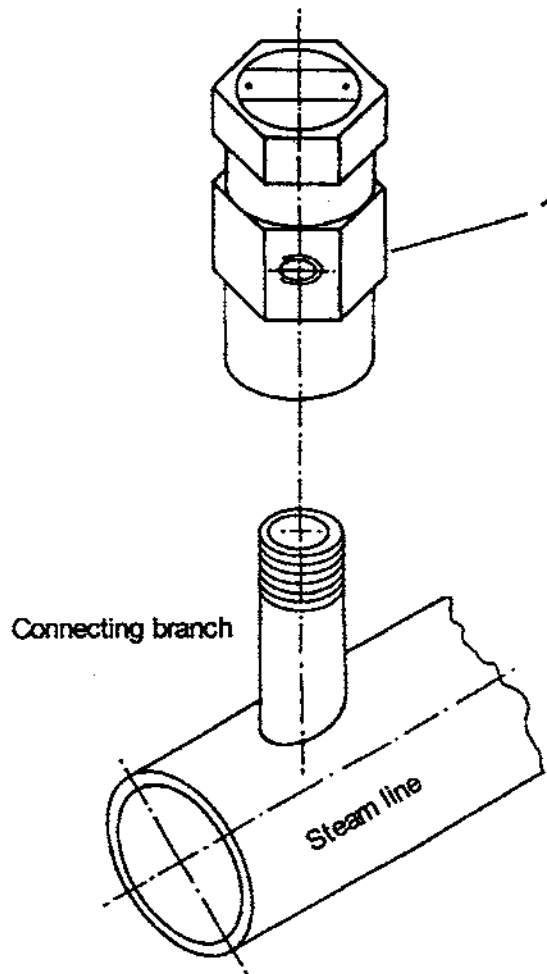

TYPE		Parts Manual		Page
LT 25 , LT 35 LT 50 , LT 60 LT 70 , LT 90		PARTS FOR STEAM LINE		9-10.4
Pos.	Part N°	Part Name	Description	Quant.
1	118 275	Breaker, Vacuum	VB 14 - ½ - Brass	1
1	118 265	Breaker, Vacuum	VB 21 - ½ - SS	1
		<p><u>Note:</u> Pos. 1 consisting of brass or SS acc. to the order</p>		

TYPE	LT 25 , LT 35 LT 50 , LT 60 LT 70 , LT 90	Parts List	PH - CONTROL	Page 9-11.0
-------------	---	------------	---------------------	----------------

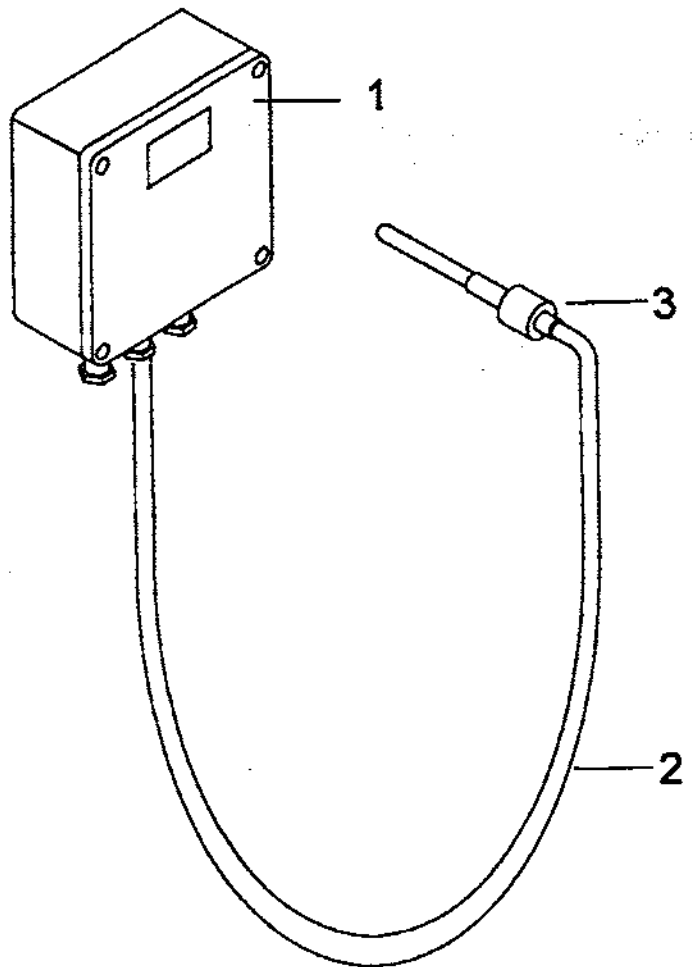

TYPE		Parts List		Page
LT 25 , LT 35 LT 50 , LT 60 LT 70 , LT 90		PH - CONTROL		9-11.1
Pos.	Part N°	Part Name	Description	Quant.
1	-	Amplifier, PH-Value	TV 02	1
2	-	Cable, Data		1
3	-	Sensor, PH-Value	pH MO 1	1

<p>TYPE LT 25 , LT 35 LT 50 , LT 60 LT 70 , LT 90</p>	<p>Parts List</p> <p>MEASURING VESSEL PH - CONTROL</p>	<p>Page 9-11.2</p>
---	--	-------------------------

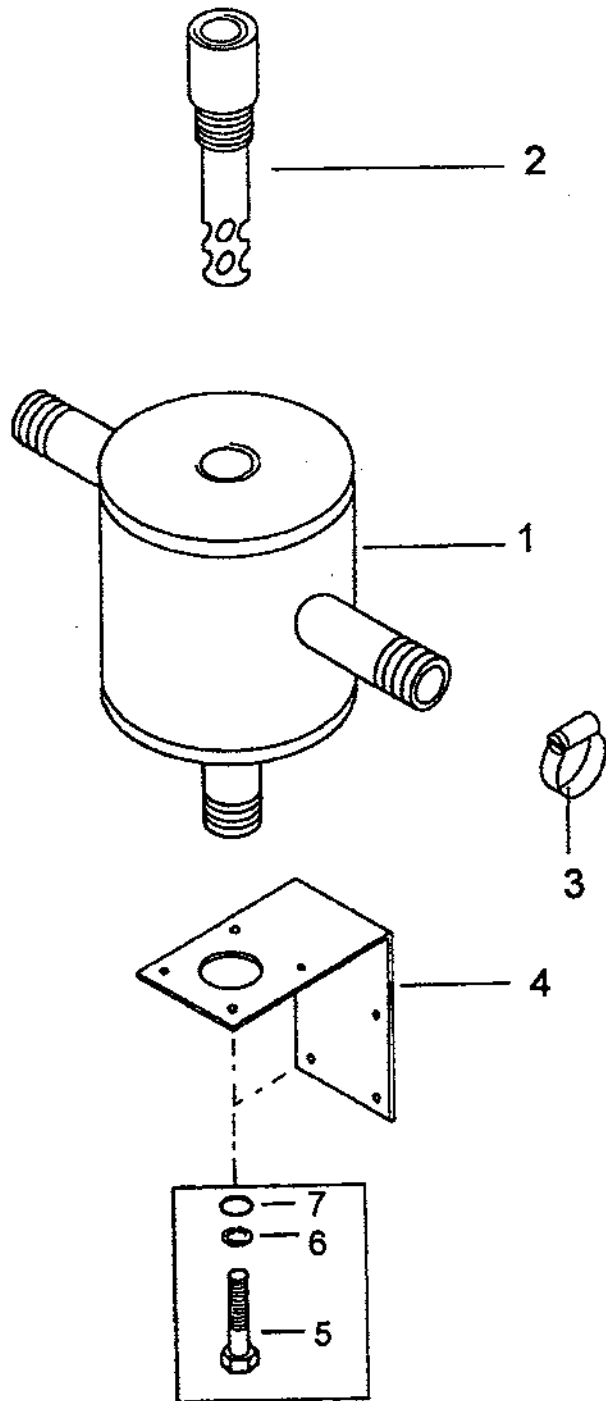

TYPE		Parts List		Page
LT 25 , LT 35 LT 50 , LT 60 LT 70 , LT 90		MEASURING VESSEL PH - CONTROL		9-11.3
Pos.	Part N°	Part Name	Description	Quant.
1	342 543-3	Vessel, PH - Measuring compl. with 3 sockets for hose DN 25 and pH-fitting pos. 2		1
2	340 791-4	PH - Fitting with inside thread Pg 13,5		1
3	121 046	Clamp, Hose	DIN 3017 AS 23 - 35 - W3	3
4	342 546-4	Bracket		1
5	020 349	Bolt, Hex	ISO 4017 M 6 x 16 - A2 - 70	8
6	020 057	Washer, Lock	DIN 128 A6 - gal.	8
7	020 046	Washer	DIN 125 6,4 - 140 HV - A2	8

TYPE LT 25 , LT 35
LT 50 , LT 60
LT 70 , LT 90

Parts List
PH - CONTROL
in the double drum area

Page
9-11.4

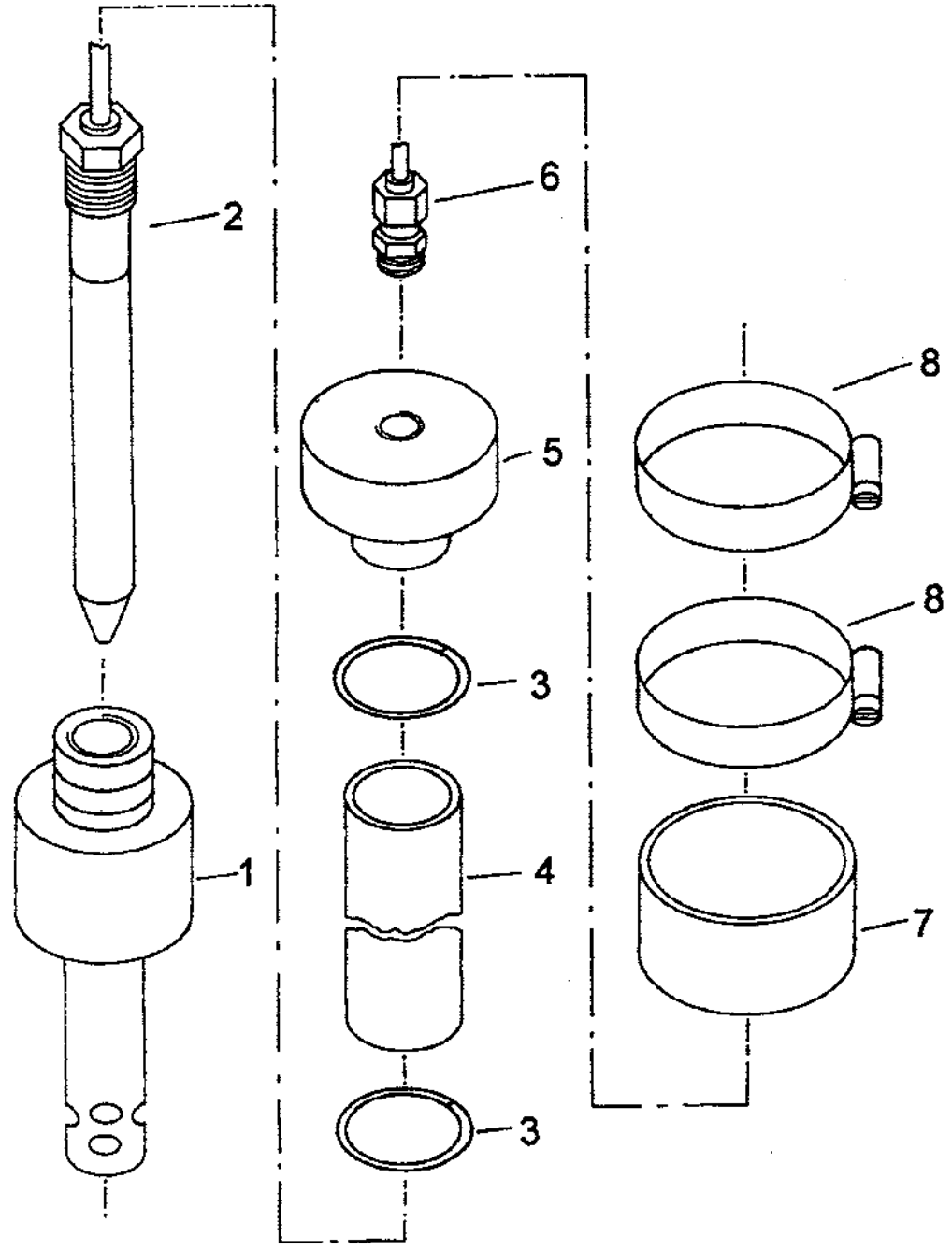

TYPE		Parts List		Page
LT 25 , LT 35 LT 50 , LT 60 LT 70 , LT 90		PH - CONTROL in the double drum area		9-11.5
Pos.	Part N°	Part Name	Description	Quant.
1	355 471-4	PH - Fitting	PVC	1
2	-	PH - Sensor and Cable	4.1.8853.001/Long	1
3	025 074	Ring, Snap	32,1 x 2,5 - 1.4301	2
4	006 012	Hose	25 x 4 x 655 - PVC	1
5	355 475-4	Piece, Connection	PVC	1
6	137 053	Joint, Cable	PG 11 - PVC	1
7	006 014	Hose	50 x 5 x 30 - PVC	1
8	121 028	Clamp, Hose	DIN 3017 AS 50 - 70 - W3	2
<p>NOTE: Valid for machines from January 1998</p>				

LT 25 , LT 35
TYPE LT 50 , LT 60
LT 70 , LT 90

Parts List
WATER PUMP

Page
9-12.0

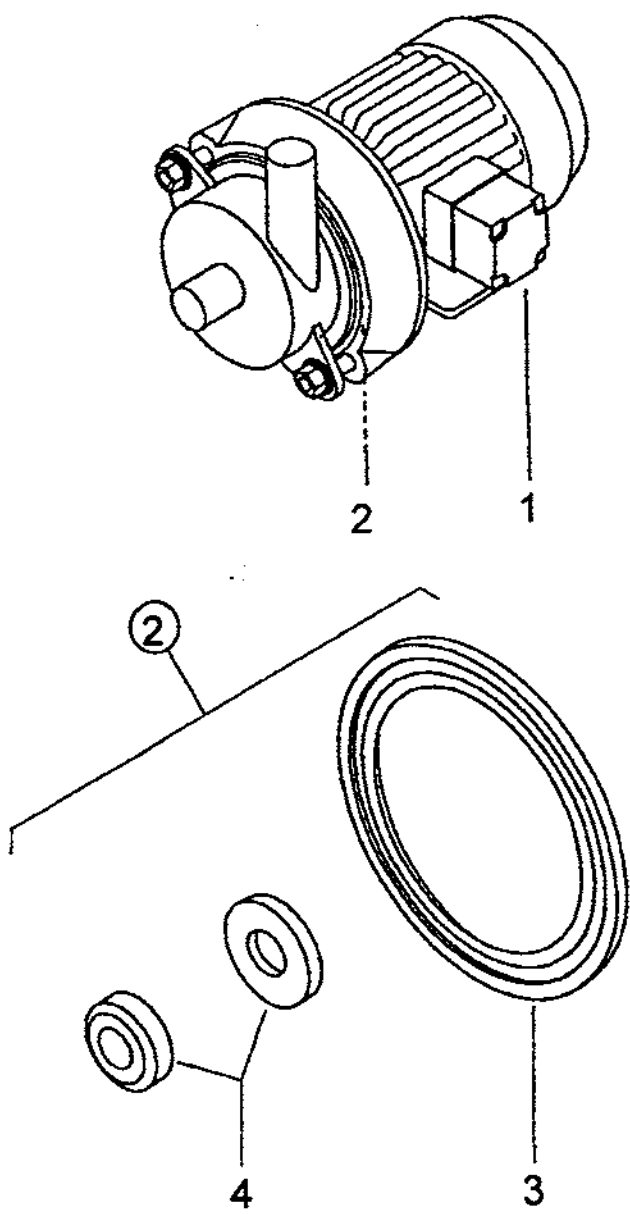

TYPE		Parts List		Page
LT 25 , LT 35 LT 50 , LT 60 LT 70 , LT 90		WATER PUMP		9-12.1
Pos.	Part N°	Part Name	Description	Quant.
1	111 339	Pump, Water	KNM 251-2/1,1	1)
2	111 590	Seal, Set, compl. consisting of pos. 3 und 4	KNM 251	1)
3	111 302	Seal, Profile Housing	KNM 251	1)
4	112 235	Seal, Rotating Mechanical	KNM 251	1)
<hr/> <p>1) Quantities as per LAVATRAC version</p> <p>NOTE:</p> <p>Part N° 111 339 for Pos. 1 is valid for types of current:</p> <p>400 V / 50 Hz 415 V / 50 Hz 460 V / 60 Hz 480 V / 60 Hz</p>				

TYPE	LT 25 , LT 35 LT 50 , LT 60 LT 70 , LT 90	Parts List	WATER CONTROL SYSTEM	Page 9-13.0
------	---	------------	----------------------	----------------

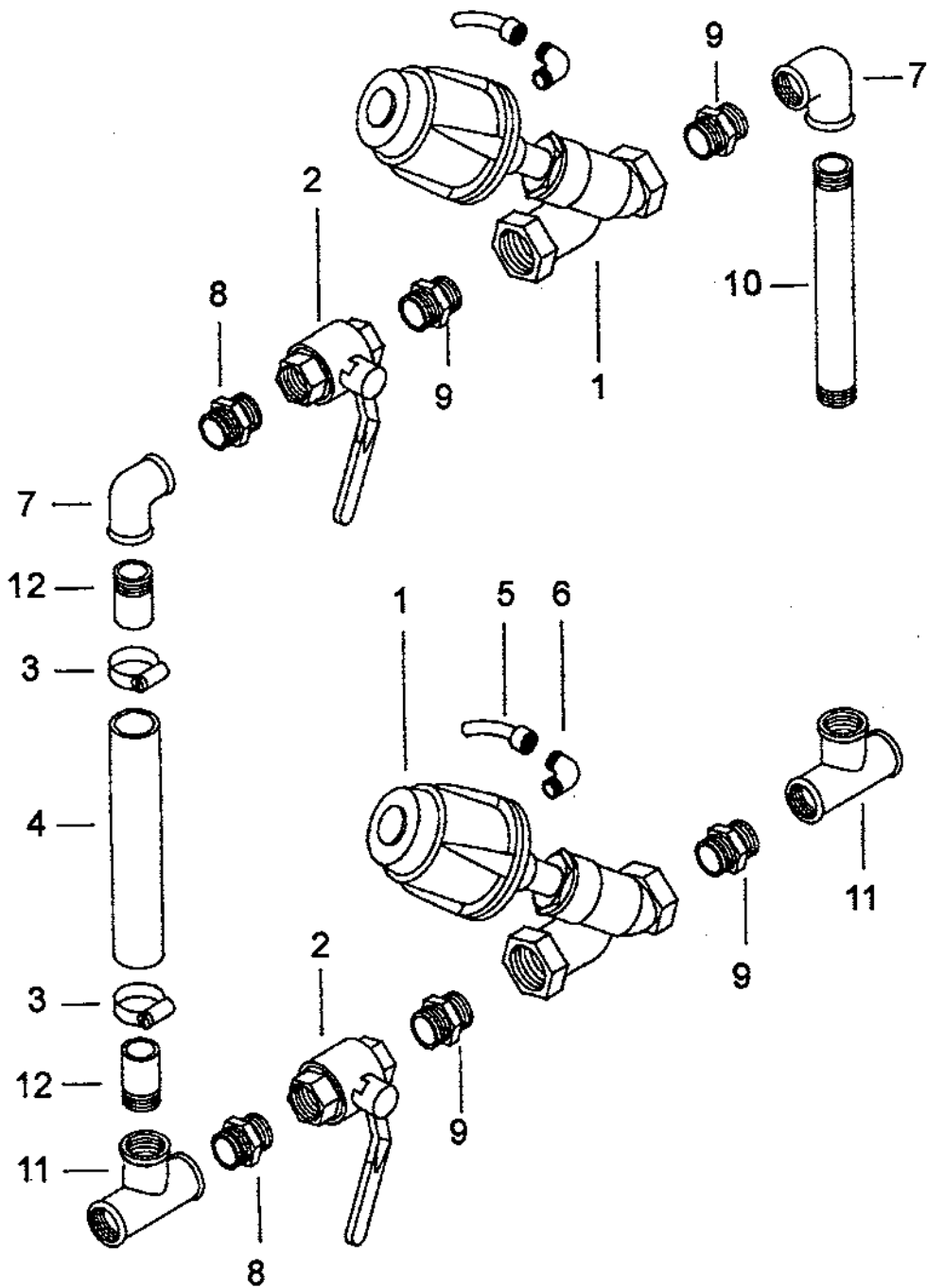

TYPE		Parts List		Page
LT 25 , LT 35 LT 50 , LT 60 LT 70 , LT 90		WATER CONTROL SYSTEM		9-13.1
Pos.	Part N°	Part Name	Description	Quant.
1	111 401	Valve; Pneumatic	DN 40	2
2	111 152	Valve, Ball	G1 , inside	2
3	121 029	Clamp, Hose	DIN 3017 AS 32 - 50 W3	2
4	006 033	Hose, with Liner	35 x 4	0,5 m
5	006 002	Hose, Air	8 x 1 - 259.12 D	
6	111 077	Coupling, Elbow	G ¼ - 8/6	2
7	030 157	Fitting, Elbow	EN 10242 A1 -1	2
8	030 108	Fitting, Straight	EN 10242 N8 - 1	2
9	030 190	Reducer	EN 10242 N8 1 ½ x 1	4
10	343 311-4	Pipe, Threaded	G 1- DN 25 x 150	1
11	030 099	T - Fitting	EN 10242 B1 - 1	2
12	340 708-4	Connector, Hose		2

LT 25 , LT 35
TYPE LT 50 , LT 60
LT 70 , LT 90

Parts List

WATER PRESSURE CONTROL

Page
9 - 14.0

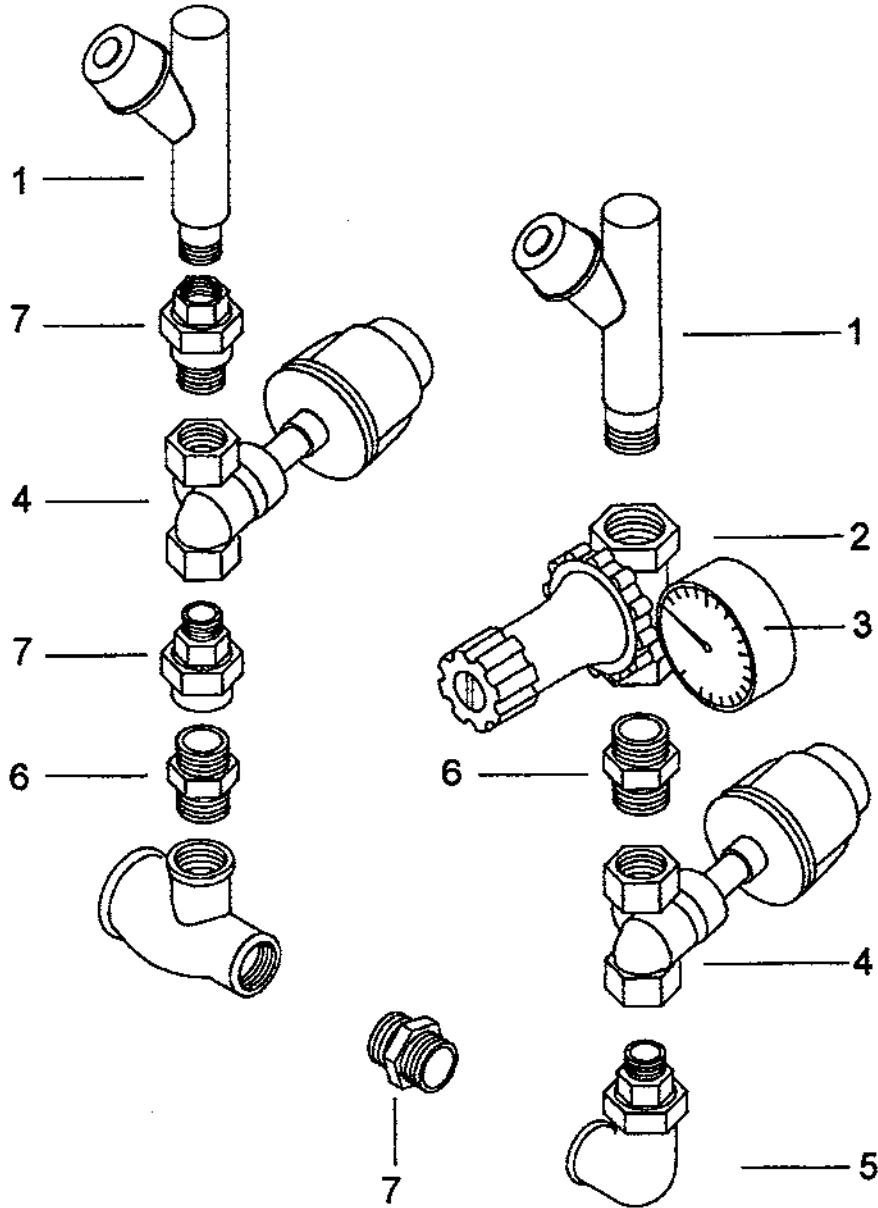

TYPE		Parts List		Page
LT 25 , LT 35 LT 50 , LT 60 LT 70 , LT 90		WATER PRESSURE CONTROL		9-14.1
Pos.	Part N°	Part Name	Description	Quant.
1	111 486	Valve, Check	54245 - DN 20	2
2	111 201	Reducer, Pressure	50 EM - G ½	1
3	111 202	Manometer	0 - 2,5 bar-G ¼ A	1
4	111 169	Valve	DN 15	2
5	030 131	Coupling, Elbow	EN 10242 UA 12 - ½	
6	030 078	Fitting, Straight	EN 10242 N 8 - ½	
7	030 136	Coupling	EN 10242 U 12 - ½	2

TYPE	LT 25 , LT 35 LT 50 , LT 60 LT 70 , LT 90	Parts List	Page
		WATER FLOW CONTROL for recovery	9 - 15.0

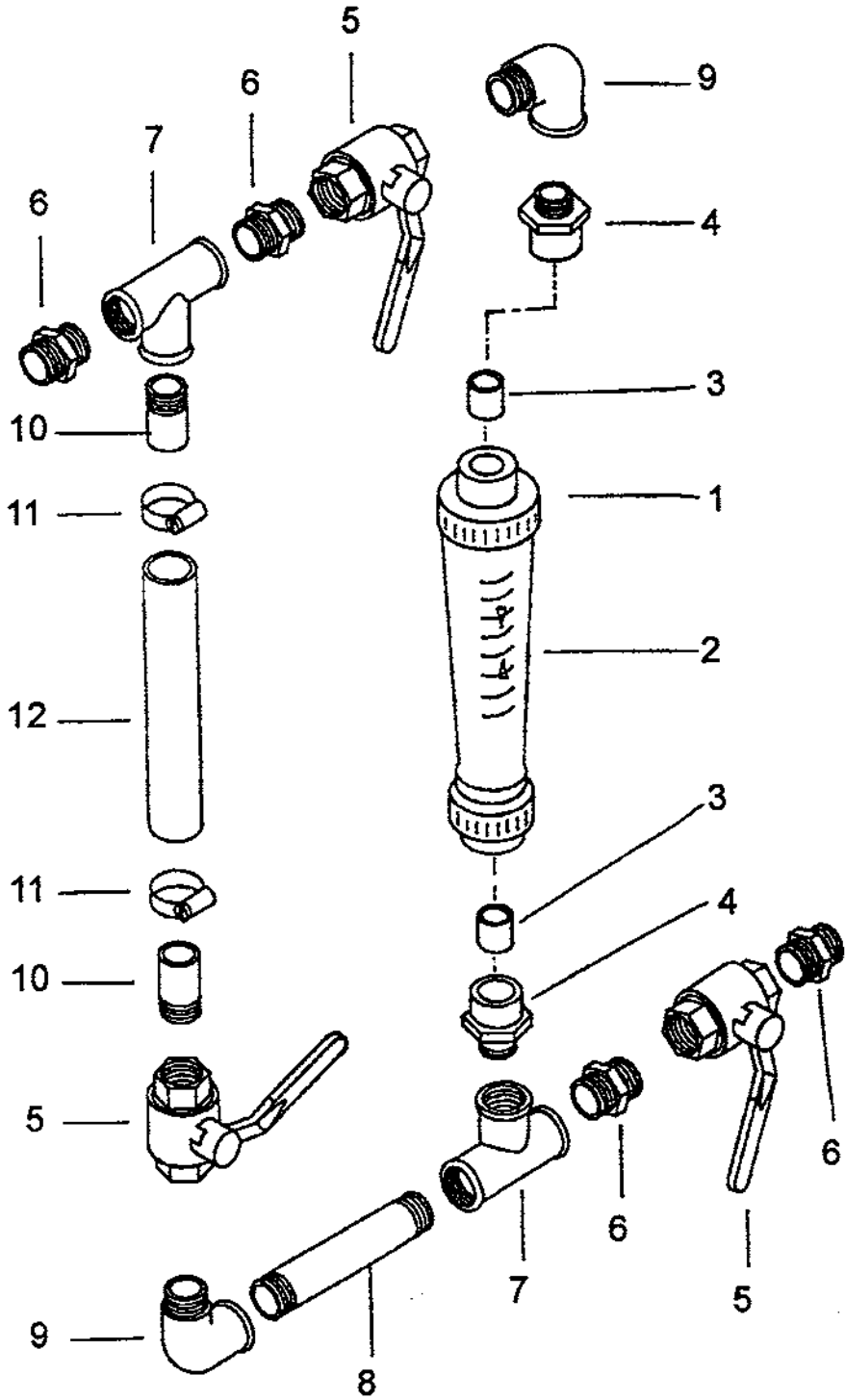

TYPE		Parts List		Page
LT 25 , LT 35 LT 50 , LT 60 LT 70 , LT 90		WATER FLOW CONTROL 0,6 - 6,4 m³/h for recovery		9-15.1
Pos.	Part N°	Part Name	Description	Quant.
1	111 171	Flow Meter, Plastic compl. incl. Pos. 2 - 4	6,4 m³/h - DN 50	1
2	112 452	Measuring Pipe incl. 2 Viton O-Rings	6,4 m³/h	1
3	030 612	Fitting, Reducing pasted with Pos. 1 + 4	63 - 40 - PVC	2
4	030 611	Nipple, Reducing pasted with Pos. 1 + 3	40 - G1 - PVC	2
5	112 347	Valve, Ball	DN 25-G1-1.4301	3
6	030 783	Fitting, Straight	G 1 - 1.4301	4
7	030 782	T - Fitting	G 1 - 1.4301	2
8	343 311-4	Fitting, Straight	G 1 - DN 25 x 150- 1.4301	1
9	030 781	Coupling, Elbow	90° - G 1 - 1.4301	2
10	340 708-4	Connector, Hose	G 1 - 35 x 75 - 1.4301	2
11	121 029	Clamp, Hose	DIN 3017 AS 32 - 50 W3	2
12	006 033	Hose, with Liner	35 x 4 x 350	1

TYPE		Parts List		Page
LT 25 , LT 35 LT 50 , LT 60 LT 70 , LT 90		WATER FLOW CONTROL 200 - 2500 L/h for recovery		9-15.2
Pos.	Part N°	Part Name	Description	Quant.
1	111 369	Flow Meter, Plastic compl. incl. Pos. 2 - 4	2500 L/h - DN 32	1
2	112 450	Measuring Pipe incl. 2 Viton O-Rings	2500 L/h - DN 32	1
4	030 611	Nipple, Reducing pasted with Pos. 1 + 3	40 - G1 - PVC	2
5	112 347	Valve, Ball	DN 25-G1-1.4301	3
6	030 783	Fitting, Straight	G 1 - 1.4301	4
7	030 782	T - Fitting	G 1 - 1.4301	2
8	343 311-4	Fitting, Straight	G 1 - DN 25 x 150- 1.4301	1
9	030 781	Coupling, Elbow	90° - G 1 - 1.4301	2
10	340 708-4	Connector, Hose	G 1 - 35 x 75 - 1.4301	2
11	121 029	Clamp, Hose	DIN 3017 AS 32 - 50 W3	2
12	006 033	Hose, with Liner	35 x 4 x 350	1

TYPE	LT 25 , LT 35 LT 50 , LT 60 LT 70 , LT 90	Parts List WATER SYSTEM FITTINGS	Page 9-16.0
------	---	--	----------------

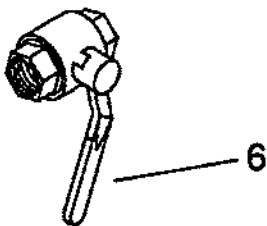
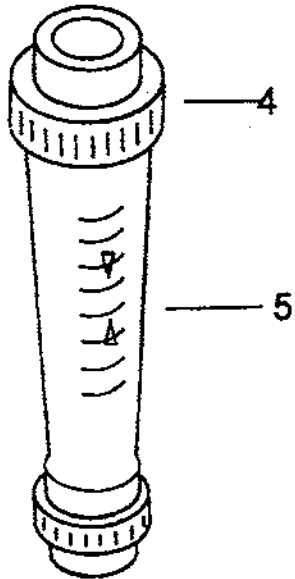
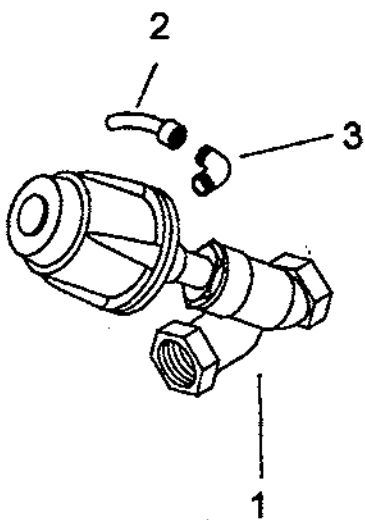

TYPE		Parts List		Page
LT 25 , LT 35 LT 50 , LT 60 LT 70 , LT 90		WATER SYSTEM FITTINGS Size Listing		9-16.1
Pos.	Part N°	Part Name	Description	Quant.
<u>Fresh Water Valves</u>				
1	111 169	Valve	DN 15 - RB	
1	111 614	Valve	DN 25 - RB	
1	111 285	Valve	DN 40 - RB	
1	111 167	Valve	DN 50 - RB	
<u>Lipour Valves</u>				
1	111 166	Valve	DN 20 - SS	
1	111 991	Valve	DN 25 - SS	
1	111 402	Valve	DN 40 - SS	
<u>Compressed Air</u>				
2	006 002	Hose, Air	8 x 1 - 259,12 D	
2	006 041	Hose, Air	6 x 1	
3	111 077	Coupling, Elbow	G ¼ - 8/6	
3	112 987	Coupling, Elbow	G ¼ - 6/4	
<u>Flow Meter</u>				
4	111 369	Flow Meter compl. incl. pos. 5 and pasted fittings: above: outside thread G 1 below: outside thread G 1	2500 L/h DN 32 - PVC	
5	112 450	Measuring Pipe incl. 2 Viton O-rings	2500 L/h	

TYPE		Parts List		Page
LT 25 , LT 35 LT 50 , LT 60 LT 70 , LT 90		WATER SYSTEM FITTINGS Size Listing		9-16.2
Pos.	Part N°	Part Name	Description	Quant.
4	111 171	Flow Meter compl. incl. pos. 5 and pasted fittings: above: outside thread G 1 below: outside thread G 1	6,4 m ³ /h DN 50 - PVC	
5	112 452	Measuring Pipe incl. 2 Viton O-rings	6,4 m ³ /h	
4	111 174	Flow Meter compl. incl. pos. 5 and pasted fittings: above: inside thread G 1 ½ below: inside thread G 1 ½	10 m ³ /h DN 50 - PVC	
5	112 453	Measuring Pipe incl. 2 Viton O-rings	10 m ³ /h	
4	112 373	Flow Meter compl. incl. pos. 5 and pasted fittings: above: inside thread G 1 ½ below: outside thread G 2	20 m ³ /h DN 65 - PVC	
5	112 454	Measuring Pipe incl. 2 Viton O-rings	20 m ³ /h	

TYPE		Parts List		Page
LT 25 , LT 35 LT 50 , LT 60 LT 70 , LT 90		WATER SYSTEM FITTINGS Size Listing		9-16.3
Pos.	Part N°	Part Name	Description	Quant.
		<u>Ball Valves</u>		
6	111 152	Valve, Ball	DN 25 - G1 - Brass	1)
6	112 347	Valve, Ball	DN 25 - G1 - 1.4301	2)
6	111 153	Valve, Ball	DN 50 - G2 - Brass	1)
		<hr/> 1) for fresh water 2) for liquor		

	LT 25 , LT 35	Parts Manual	Page
TYPE	LT 50 , LT 60	SAMPLING SYSTEM	9 - 17.0
	LT 70 , LT 90		

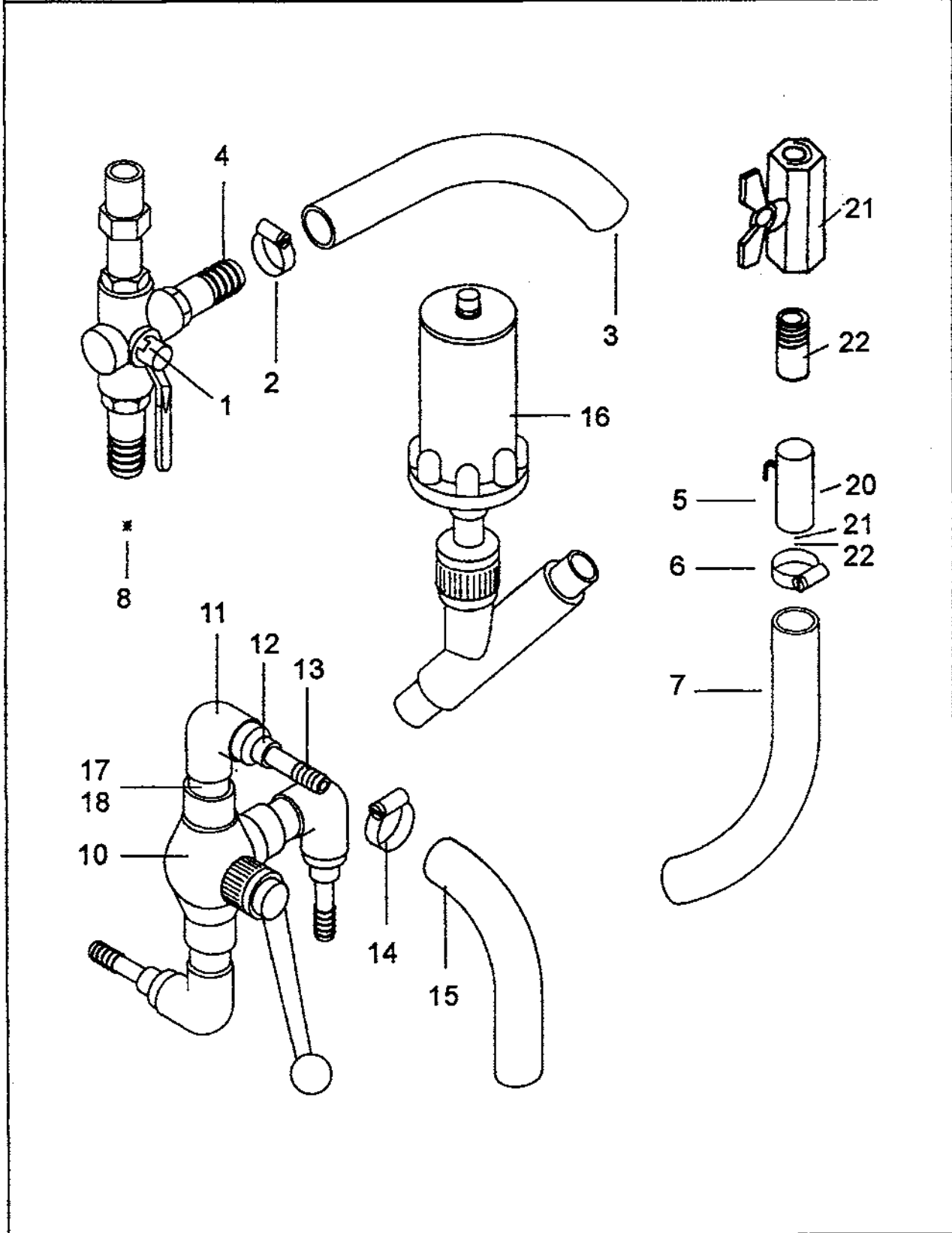

TYPE		Parts Manual		Page
LT 25 , LT 35 LT 50 , LT 60 LT 70 , LT 90		SAMPLING SYSTEM		9-17.1
Pos.	Part N°	Part Name	Description	Quant.
1	111 113	Valve, Three-Way Ball	G ½ - Brass	1
2	121 046	Clamp, Hose DIN 3017	AS 23 - 35 W3	2
3	006 032	Hose, Rubber	19 x 4	1
4	340 727-4	Connector, Barbed		2
5	340 516-4	Funnel		1
6	121 029	Clamp, Hose DIN 3017	AS 32 - 50 W3	1
7	006 012	Hose, PVC with Textile Liner	25 x 4 x 1000	1
<u>Version with dosing valve</u>				
8	111 166	Valve	DN 20 - SS	1
<u>OPTION: Outlet with ball valve</u>				
20	353 440-4	Funnel (with outside thread G ½)		1)
21	112 461	Valve, Ball	G ½ - I	1)
22	340 877-4	Stem, Hose		1)
<hr/> 1) Quantities as number of compartments in the double drum area.				

TYPE		Parts Manual		Page
LT 25 , LT 35 LT 50 , LT 60 LT 70 , LT 90		SAMPLING SYSTEM Plastic Valves Assembly		9-17.2
Pos.	Part N°	Part Name	Description	Quant.
<u>Sampling Valve DN 10 Line</u>				
10	111 479	Valve, Three - Way , PVC	51955, DN 15	1
11	030 113	Coupling, Elbow 90°	53010, DN 15	3
12	030 118	Reducer	53552, DN 15 - 8	3
13	030 119	Connector, Barbed dia. 12	53696, DN 8	3
14	121 045	Clamp, Hose DIN 3017	AL 12 - 22 W3	3
15	006 021	Hose, PVC with Textile Liner	10 x 3	
<u>DN 10 Line with Control Valve</u>				
16	111 493	2/2 - Control Valve	150-A-015-A Klever-PVO-1-000	1
<u>Sampling Valve DN 25 Line</u>				
10	111 485	Valve, Three - Way , PVC	51956, DN 25	1
11	030 220	Coupling, Elbow 90°	53011, DN 20	3
12	030 194	Socket	53420, DN 25	3
13	030 138	Connector, Barbed dia. 25	53699, DN 20	3
14	121 046	Clamp. Hose DIN 3017	AS 23 - 35 W3	3
15	006 012	Hose, PVC with Textile Liner	25 x 4	
17	030 221	Reducer	53559, DN 25 - 20	3
18	005 012	Tube, PVC	25 x 1,5 x 40	3

TYPE LT 25 , LT 35 LT 50 , LT 60 LT 70 , LT 90	Parts Manual SAMPLE POCKETS ON THE DRUM (Option)	Page 9 - 17.3
--	--	-------------------------

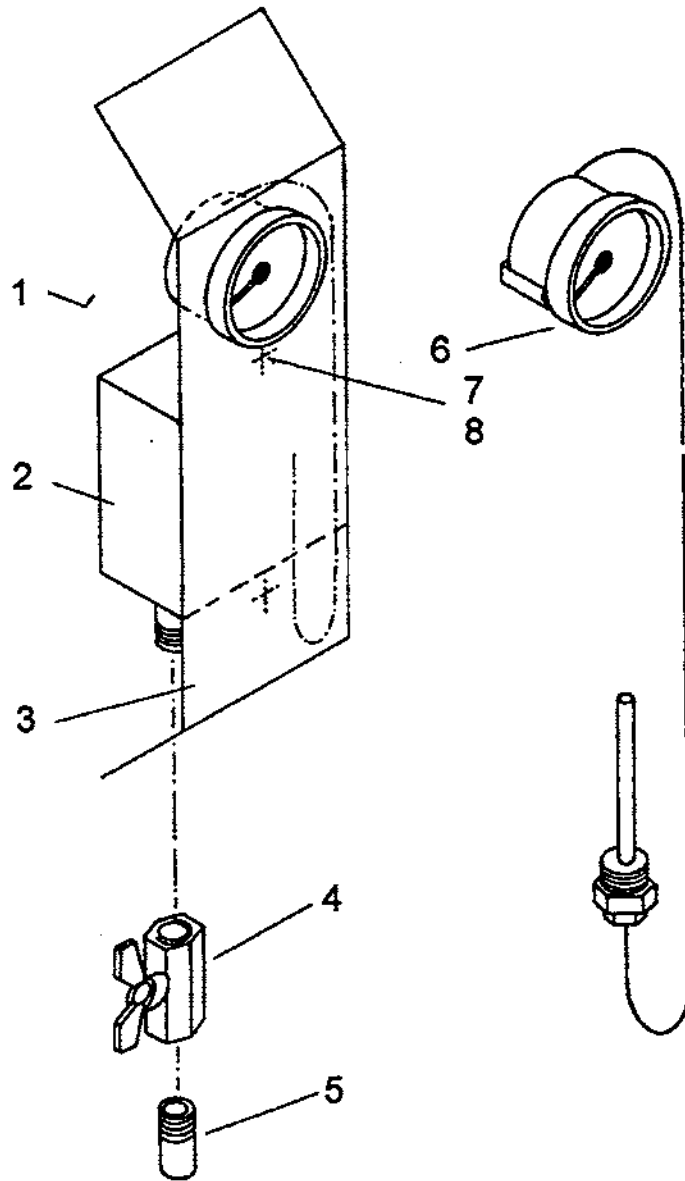

TYPE		LT 25 , LT 35 LT 50 , LT 60 LT 70 , LT 90		Parts Manual	SAMPLE POCKETS ON THE DRUM (Option)		Page
Pos.	Part N°	Part Name		Description	Quant.		
1		Drum					
2	-	Pocket, Sample			1)		
3	-	Sheet, Cover					
4	111 476	Valve, Ball		R 3/8 - 1.4301	1		
5	030 355	Nipple		3/8 x 30 - 1.4301	1		
6	118 053	Thermometer, Distance		JFC 01 - 060 KF	1		
7	020 312	Screw, Pan Head	DIN 84	M 6 x 25 - Brass-gal.	2		
8	020 311	Washer	DIN 125	A6,4 - Brass-gal.	2		
		<hr/> 1) Quantities as per order					

LT 25 , LT 35
TYPE LT 50 , LT 60
LT 70 , LT 90

Parts Manual

RINSE WATER INLET MANIFOLD

Page
9-18.0

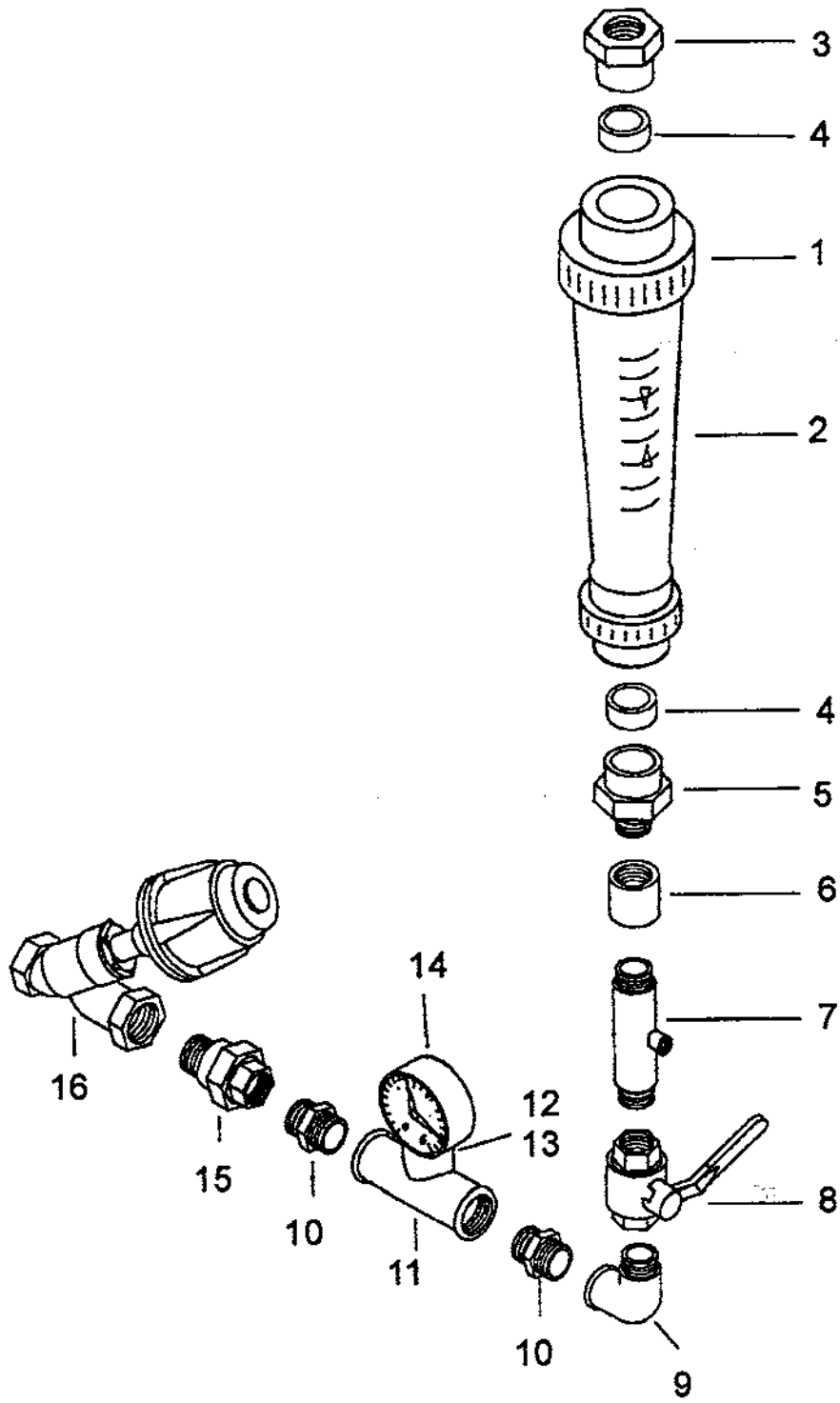

TYPE		Parts Manual		Page
LT 25 , LT 35 LT 50 , LT 60 LT 70 , LT 90		RINSE WATER INLET MANIFOLD		9-18.1
Pos.	Part N°	Part Name	Description	Quant.
1	112 373	Flow Meter compl. incl. pos. 3 - 5	20 m³/h - DN 65	1
2	112 454	Measuring Pipe incl. 2 O-rings	20 m³/h - DN 65	1
3	030 592	Nipple, Reducing pasted with pos. 4	63 - G 1 ½ - PVC	1
4	030 591	Fitting, Reducing pasted with pos. 1 + 3 resp. 1 + 5	75 - 63 - PVC	2
5	030 593	Nipple, Reducing pasted with pos. 4	63 - G 2 - PVC	1
6	030 590	Coupling	G 2 -1.4301	1
7	340 716-4	Pipe, Injector compl.		1
8	111 153	Valve, Ball	DN 50-G 2-Brasss	1
9	030 563	Coupling, Elbow	3092 - G 2 - RB	1
10	030 575	Fitting, Straight	3280 - G 2 - RB	2
11	030 550	T - Fitting	3130 - 2-1-2 - RB	1
12	030 568	Nipple, Reducing	3241 - 1 ½ -RB	1
13	030 584	Fitting, Union	3341 - ½ - RB	1
14	111 512	Switch, Pressure	0 - 6 bar - G ½	1
15	030 586	Fitting, Union	3341 - G 2 - RB	1
16	111 167	Valve	DN 50 - RB	1

LT 25 , LT 35
TYPE LT 50 , LT 60
LT 70 , LT 90

Parts List

**INJECTOR ASSEMBLY
UNLOADING SIDE**

Page
9-19.0

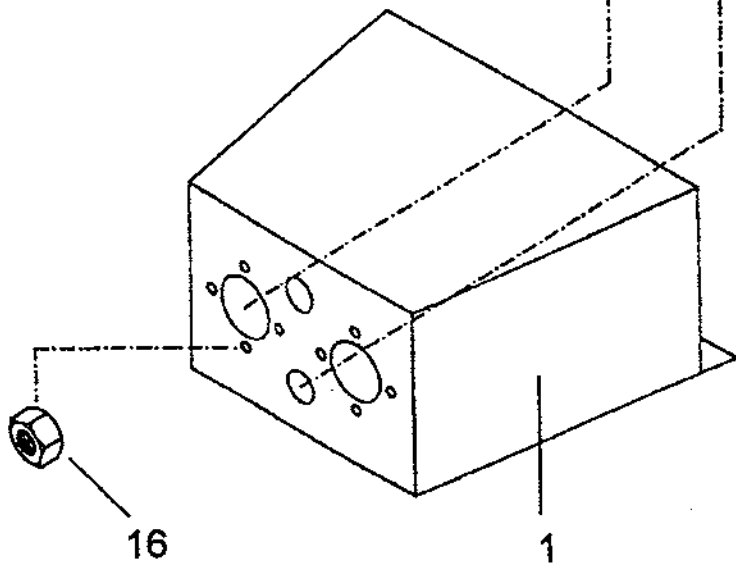
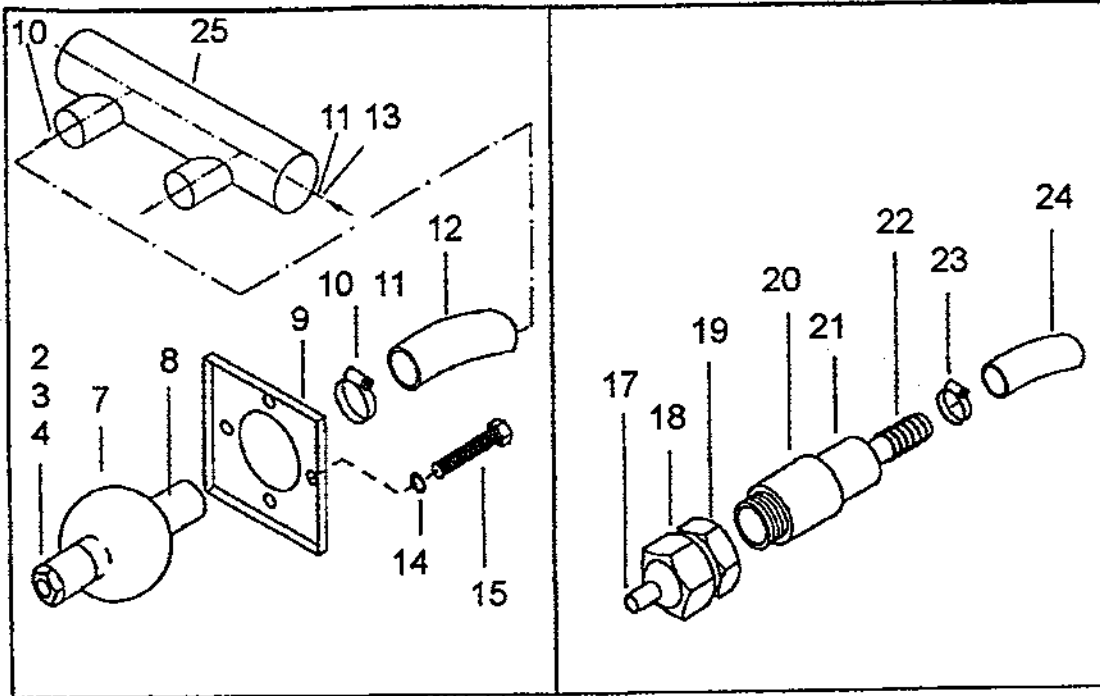

TYPE		Parts List		Page
LT 25 , LT 35 LT 50 , LT 60 LT 70 , LT 90		INJECTOR ASSEMBLY UNLOADING SIDE		9-19.1
Pos.	Part N°	Part Name	Description	Quant.
1	341 171-3	Holder, Injector	LT 25 + 35	1
1	340 705-3	Holder, Injector	LT 50 + 60	1
2	116 023	Injector, Main Size 10,5	545 200	
		LT 25 x 5 bis 10 1 Piece		
		LT 35 x 5 bis 7 1 Piece		
		LT 50 x 5 1 Piece		
3	116 022	Injector, Main Size 13,3	545 280	
		LT 25 x 11 bis 18 1 Piece		
		LT 35 x 8 bis 12 1 Piece		
		LT 35 x 19 und 20 2 Piece		
		LT 50 x 6 bis 8 1 Piece		
		LT 50 x 14 bis 17 2 Piece		
		LT 60 x 5 bis 7 1 Piece		
		LT 60 x 8 bis 14 2 Piece		
4	116 006	Injector, Main Size 16,6	545 360	
		LT 25 x 19 und 20 1 Piece		
		LT 35 x 13 bis 18 1 Piece		
		LT 50 x 9 bis 13 1 Piece		
		LT 50 x 18 bis 20 2 Piece		
		LT 60 x 15 bis 20 2 Piece		
7	340 706-4	Joint, Ball		
8	349 057-4	Connector, Hose (present if pos. 2-4 = 2 Pieces)	G 1 x 35	*)
8	341 891-4	Connector, Hose (present if pos. 2-4 = 1 Piece)	G 1 x 50	*)
9	340 707-4	Bracket, Stiffener		*)
		*) Quant. acc. pos. 2 - 4		

LT 25 , LT 35 TYPE LT 50 , LT 60 LT 70 , LT 90	Parts List INJECTOR ASSEMBLY UNLOADING SIDE	Page 9-19.2
---	---	----------------

Pos.	Part N°	Part Name	Description	Quant.
10	121 029	Clamp, Hose DIN 3017 (present if pos. 2 = 2 Pieces)	AS 32 - 50 W3	2 ¹⁾
11	121 028	Clamp, Hose DIN 3017 (present if pos. 2 = 1+2 Pieces)	AS 50 - 70 W3	1 ¹⁾
12	006 033	Hose, Textile Liner (vorh. wenn Pos. 2 = 2 Stück)	35 x 4 x 300	1 ¹⁾
13	006 014	Gewebeschiauch (vorh. wenn Pos. 2 = 1+2 Stück)	50 x 4 x 2000	1 ¹⁾
14	020 055	Washer, Lock DIN 128	A 6 - 1.4310	4 ¹⁾
15	020 374	Bolt, Hex ISO 4017	M 6 x 50 - A2	4 ¹⁾
16	020 031	Nut, Hex ISO 4032	M 6 - A2	4 ¹⁾
17	116 007	Injector, Main VK1	676 880 16	1
18	116 008	Nut, Cap for pos. 17	092 030 16 00 05	1
19	116 009	Connector for pos. 17	092 030 16 00 02	1
20	030 121	Adapter	3/8 - 20	1
21	030 118	Reducer	20 - 12	1
22	030 119	Connector, Hose	12	1
23	121 045	Clamp, Hose DIN 3017	AL 12 - 22 W3	1
24	006 021	Hose, Textile Liner	10 x 3	1,5 m
25	340 710-4	Manifold (present if pos. 2 = 2 Pieces)	50 / 2 x 35	1

¹⁾ multiply with the number of
pos. 2 to 4

TYPE LT 25 , LT 35 LT 50 , LT 60 LT 70 , LT 90	Parts List DOSING MANIFOLD	Page 9-20.0
---	--	--------------------

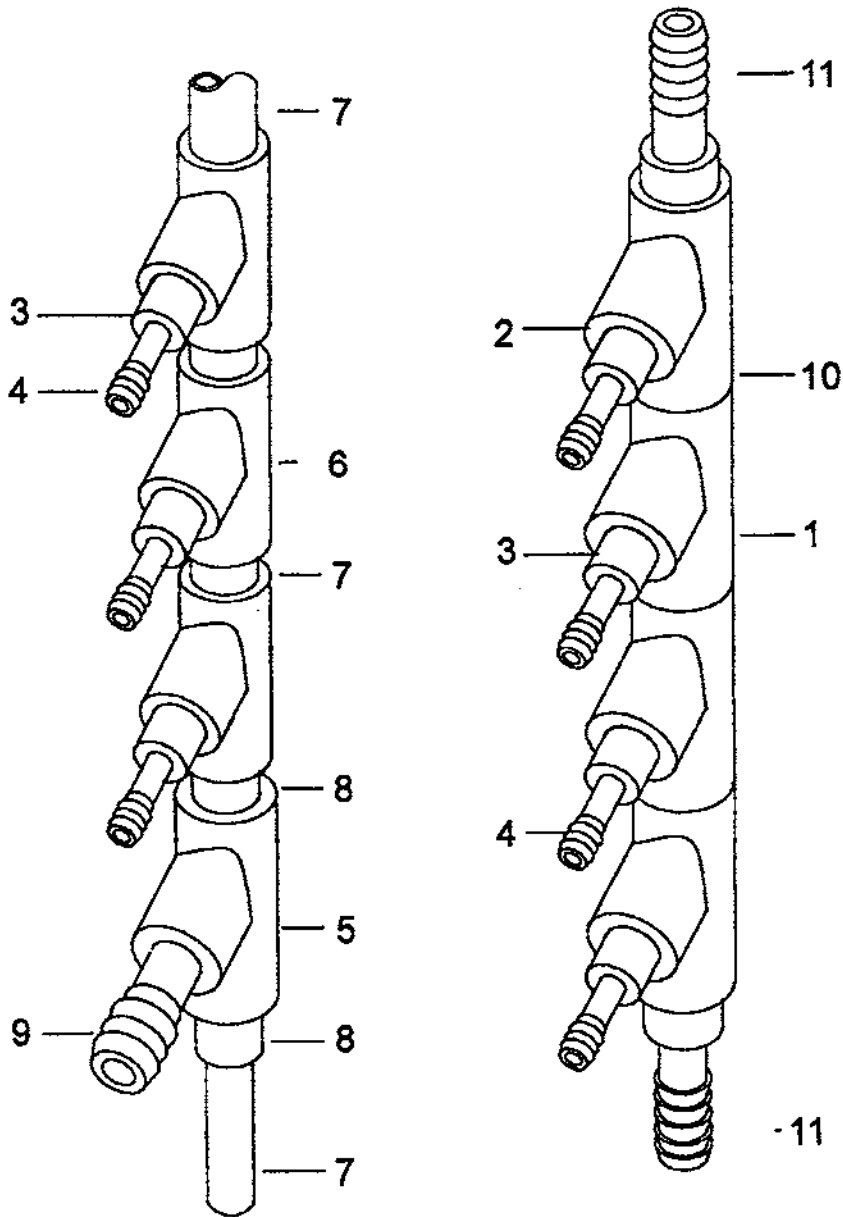

TYPE		Parts List		Page
LT 25 , LT 35 LT 50 , LT 60 LT 70 , LT 90		DOSING MANIFOLD		9-20.1
Pos.	Part N°	Part Name	Description	Quant.
1	030 151	Branch	A 53147 - DN 50	
2	030 153	Reducer, short	A 53521 - 50 - 20	
3	030 118	Reducer, long	D 53552 - 20 - 12	
4	030 119	Connector, Hose	D 53696 - 12	
5	030 139	Branch	D 53144 - 25	
6	030 115	Branch	D 53143 - 20	
7	005 009	PVC - Pipe	52855 - 20 x 1,5	
8	030 117	Reducer	A 53509 - 25 - 20	
9	030 138	Connector, Hose	D 53699 - 25	
10	005 030	PVC - Pipe	52833 - 50 x 2	
11	030 154	Connector, Hose	D 53703 - 50	
<p>NOTE: The combination of the pieces are exemplary. If ordering, the pieces must put together acc. to the design of LAVATRAC</p>				

LT 25 , LT 35
TYPE LT 50 , LT 60
LT 70 , LT 90

Parts Manual

LEVEL CONTROL WEIR BOX

Page
9 - 21.0

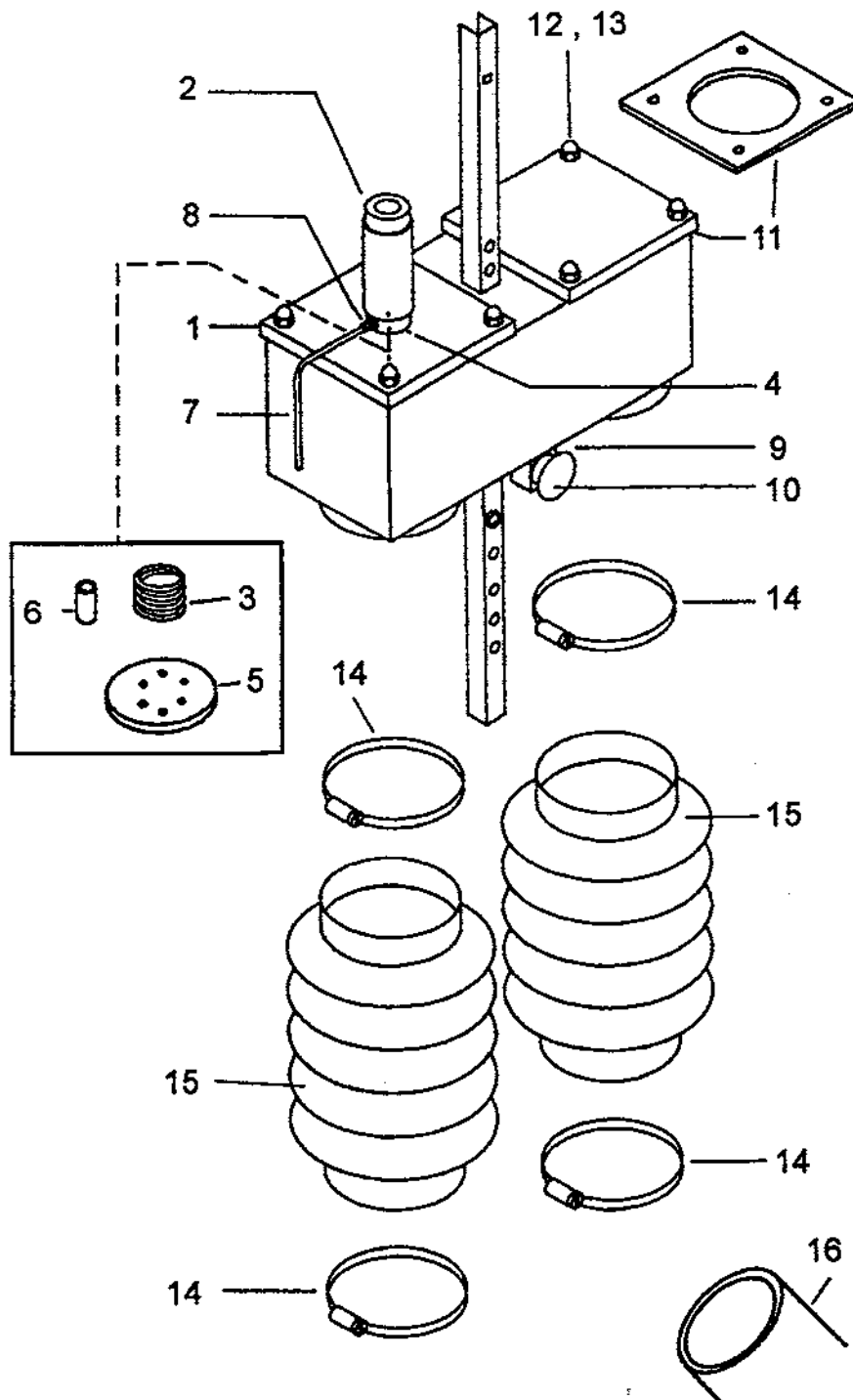

TYPE		Parts Manual		Page
LT 25 , LT 35 LT 50 , LT 60 LT 70 , LT 90		LEVEL CONTROL WEIR BOX		9-21.1
Pos.	Part N°	Part Name	Description	Quant.
1		Tank, Level Control		1
2	111 192	Cylinder, Pneumatic	RDK 2040 - 0050	1
3	027 010	Spring	VD - 314	1
4	028 113	O - Ring	36 x 4	1
5	340 407-4	Seal, Rubber	115 x 6	1
6	030 642	Tube, Distance	8,4 x 17 x 25	3
7	006 002	Hose, Air	8 x 1	1
7	006 041	Hose, Air	6 x 1	1
8	111 098	Coupling, Straight	G ¼ - 8/6	1
8	112 984	Coupling, Straight	G ¼ - 6/4	1
9	027 011	Spring	VD 153 A	1
10	125 003	Knob	Ø 33 - M 8	1
11	340 553-4	Seal, Rubber	2 x 143 x 153	2
12	020 373	Nut, Cap	DIN 1587 M 6	8
13	028 090	Gasket	Nola M 6	8
14	121 107	Clamp, Hose	DIN 3017 B1 - 107 x 15 - W4	4
15	342 470-4	Bellows	028 123	2
16	006 044	Hose	100 x 6 x 1000	

LT 25 , LT 35
TYPE LT 50 , LT 60
LT 70 , LT 90

Parts Manual

LEVEL CONTROL Weir Box, Inner Parts

Page
9 - 21.2

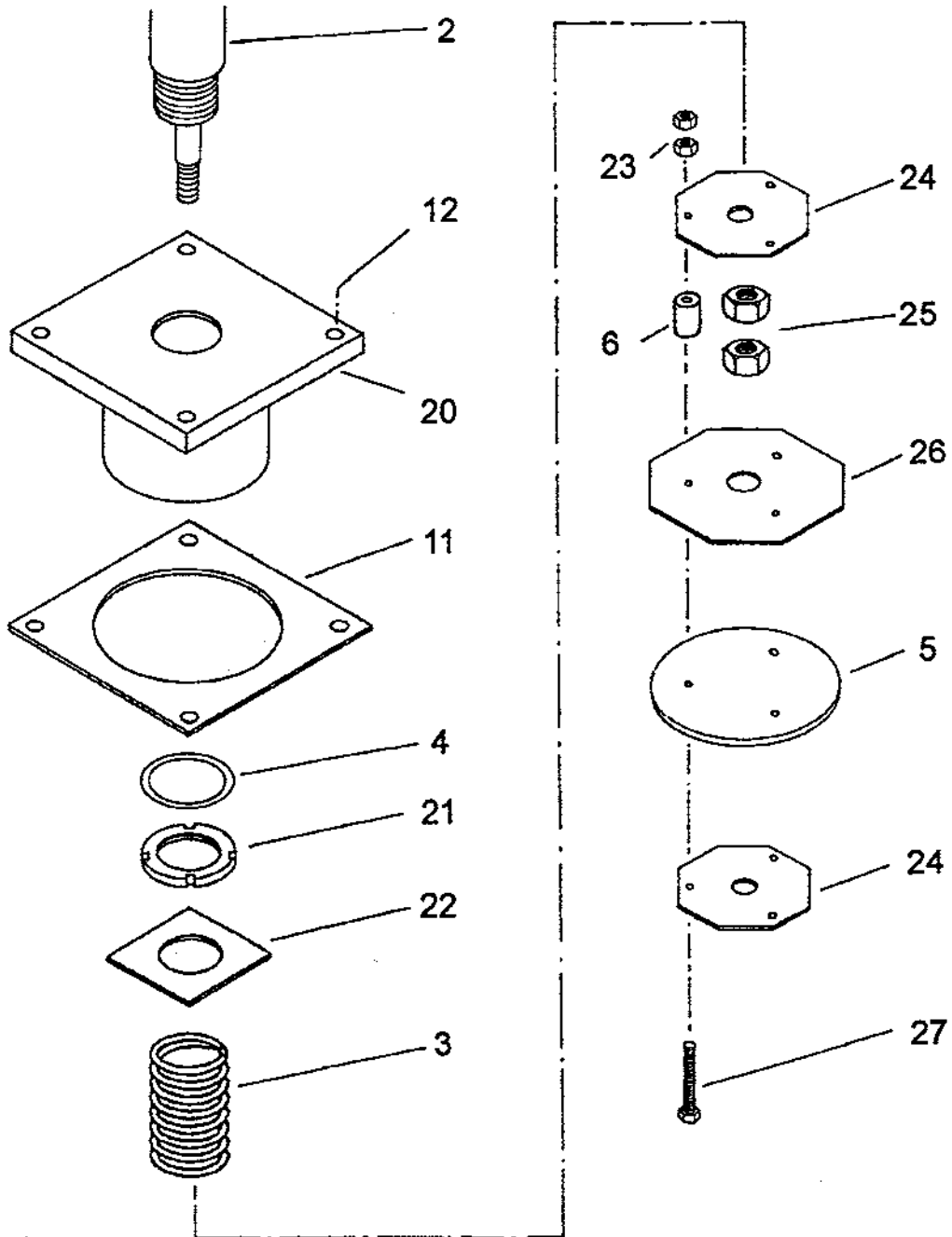

See also page 9-21.1

TYPE		Parts Manual			Page
LT 25 , LT 35 LT 50 , LT 60 LT 70 , LT 90		LEVEL CONTROL Weir Box, Inner Parts			9-21.3
Pos.	Part N°	Part Name	Description	Quant.	
<u>Pos. 2-6 and 11-13 see Page. 9-21.1</u>					
20	342 499-4	Cover, Top		1	
21	-	Nut, Slotted Round (included in Pos. 2)	M 28 x 1,5	1	
22	340 550-4	Retainer, Spring		1	
23	020 031	Nut, Hex	ISO 4032 M 6 - A2	6	
24	340 549-4	Sheet, Support		1	
25	020 360	Nut, Hex	ISO 4032 M 12 - A2	2	
26	340 548-4	Retainer, Seal		1	
27	020 374	Bolt, Hex	ISO 4017 M 6 x 50 - A2 - 70	3	

LT 25 , LT 35
TYPE LT 50 , LT 60
LT 70 , LT 90

Parts Manual

LEVEL CONTROL FOR WEIR BOX Pneumatic

Page
9 - 21.4

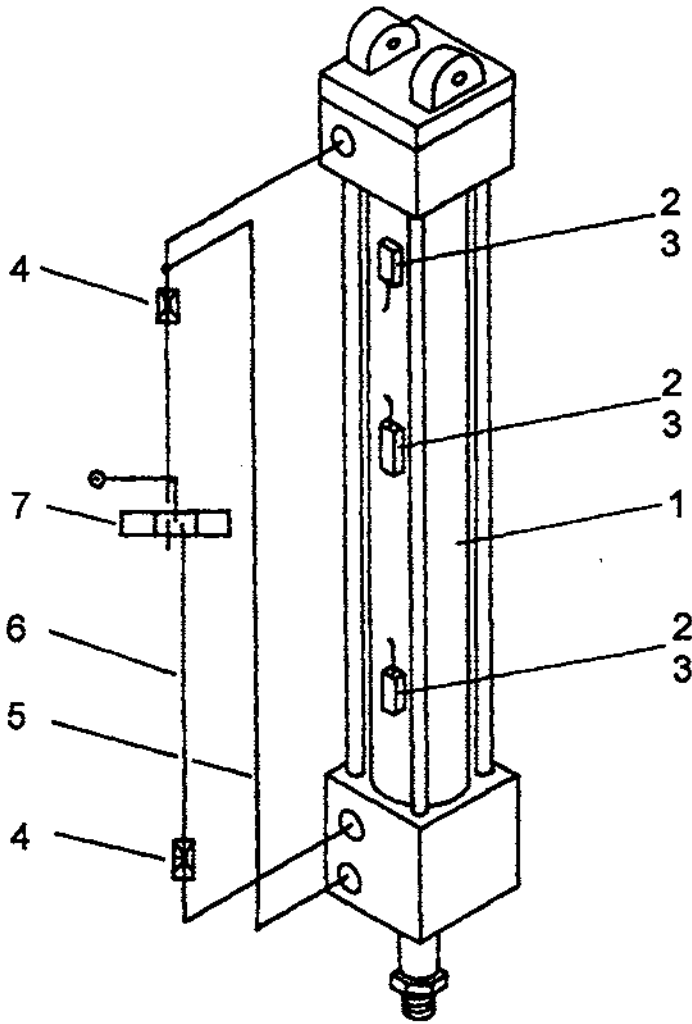

TYPE		Parts Manual		Page
LT 25 , LT 35 LT 50 , LT 60 LT 70 , LT 90		LEVEL CONTROL FOR WEIR BOX Pneumatic		9-21.5
Pos.	Part N°	Part Name	Description	Quant.
1	112 519	Cylinder, Pneumatic	DZBA 50032/0200	1
2	112 520	Switch, Magnetic (Reed-Contact)	RRK - KY 3227	3
3	112 521	Strap, Tightening	KLAR 12 - KY 3244	3
4	112 164	Valve, Choker	DV 1/8	2
5	006 046	Hose	259.09 N - 4 x 1	
6	006 002	Hose	259.12 D - 8 x 1	
7	112 522	Valve 5/3 - Way	S 9581 RFE- 1/8 - 61	1
		<u>Note:</u> Weir box part see page 9-21.0 to 9-21.3		

LT 25 , LT 35
TYPE LT 50 , LT 60
LT 70 , LT 90

Parts Manual

LEVEL CONTROL OF WASHING TANK
conductive

Page

9 - 22.0

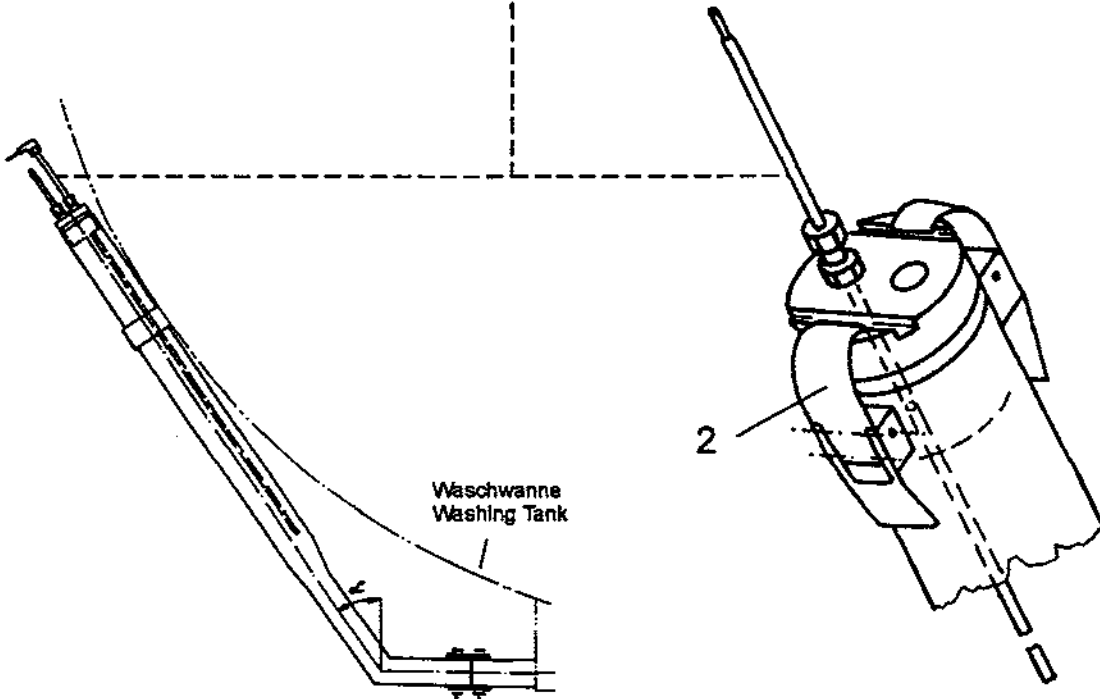
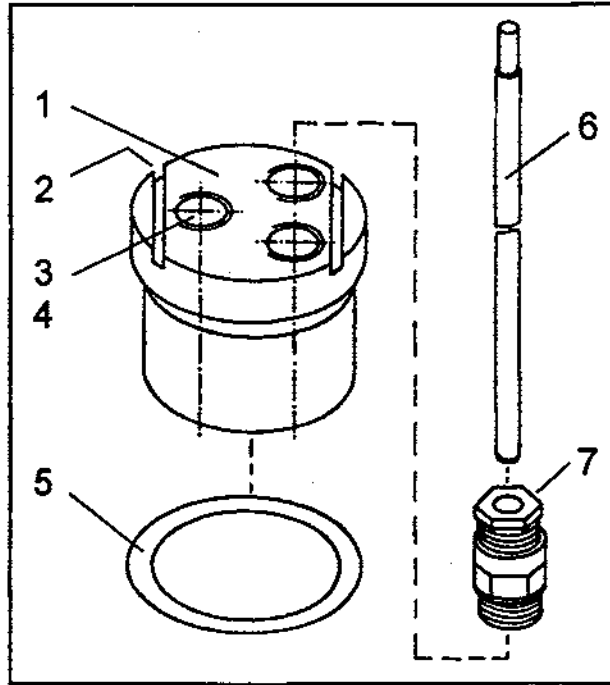

TYPE		Parts Manual		Page
LT 25 , LT 35 LT 50 , LT 60 LT 70 , LT 90		LEVEL CONTROL OF WASHING TANK conductive		9-22.1
Pos.	Part N°	Part Name	Description	Quant.
		<u>Design for one level</u>		
	360 466-4	Switch, Level, compl.	LT 25/35 BT Washing zone	1
6	360 482-4	Sensor, compl.	550 long, red	1
	360 467-4	Switch, Level, compl.	LT 25/35 BT Rinsing zone	1
6	360 485-4	Sensor, compl.	505 long, red	1
	353 810-4	Switch, Level, compl.	LT 50/60 BT Washing zone	1
6	353 815-4	Sensor, compl.	620 long, red	1
	360 465-4	Switch, Level, compl.	LT 50/60 BT Rinsing zone	1
6	360 482-4	Sensor, compl.	550 long, red	1
	360 469-4	Switch, Level, compl.	LT 70/90 BT, 50 CT W- and R-zone	1
6	360 497-4	Sensor, compl.	450 long, red	1
	360 468-4	Switch, Level, compl.	LT 35 CT W- and R-zone	1
6	360 493-4	Sensor, compl.	525 long, red	1
1	353 595-4	Retainer		1
2	121 243	Catch, Bayonet		2
3	006 002	Hose	8 x 1	1
4	360 574-4	Tube	6 x 1 x 50	1
5	358 449-4	Seal	d=51 x d= 41 x 4	1
6		See above		
7	137 644	Joint, Cable	Pg 7	2

TYPE		Parts Manual		Page
LT 25 , LT 35 LT 50 , LT 60 LT 70 , LT 90		LEVEL CONTROL OF WASHING TANK conductive		9-22.2
Pos.	Part N°	Part Name	Description	Quant.
		<u>Design for two levels</u>		
	360 506-4	Switch, Level, compl.	LT 25/35 BT Washing zone	1
6	360 507-4	Sensor, compl.	450 long, black	1
6	360 482-4	Sensor, compl.	550 long, red	1
	360 510-4	Switch, Level, compl.	LT 25/35 BT Rinsing zone	1
6	360 485-4	Sensor, compl.	505 long, red	1
6	360 511-4	Sensor, compl.	405 long, black	
	353 811-4	Switch, Level, compl.	LT 50/60 BT Washing zone	1
6	353 815-4	Sensor, compl.	620 long, red	1
6	360 816-4	Sensor, compl.	525 long, black	1
	360 499-4	Switch, Level, compl.	LT 50/60 BT Rinsing zone	1
6	360 470-4	Sensor, compl.	575 long, red	1
6	360 500-4	Sensor, compl.	475 long, black	1
	360 518-4	Switch, Level, compl.	LT 70/90 BT, 50 CT W- and R-zone	1
6	360 497-4	Sensor, compl.	450 long, red	1
	360 519-4	Sensor, compl.	350 long, black	1
	360 514-4	Switch, Level, compl.	LT 35 CT W- and R-zone	1
6	360 493-4	Sensor, compl.	525 long, red	1
6	360 515-4	Sensor, compl.	425 long, black	1

LT 25 , LT 35 TYPE LT 50 , LT 60 LT 70 , LT 90	Parts Manual LEVEL CONTROL OF WASHING TANK conductive	Page 9-22.3
---	--	----------------

Pos.	Part N°	Part Name	Description	Quant.
		<u>Design for two levels</u>		
1	353 595-4	Retainer		1
2	121 243	Catch, Bayonet		2
3	006 002	Hose	8 x 1	1
4	360 574-4	Tube	6 x 1 x 50	1
5	358 449-4	Seal	d=51 x d= 41 x 4	1
6		See page before		
7	137 644	Joint, Cable	Pg 7	3

TYPE		Parts Manual		Page
LT 25 , LT 35 LT 50 , LT 60 LT 70 , LT 90		LEVEL CONTROL OF WASHING TANK conductive		9-22.4
Pos.	Part N°	Part Name	Description	Quant.
		<u>Design for three levels</u>		
	360 526-4	Switch, Level, compl.	LT 25/35 BT Washing zone	1
6	360 482-4	Sensor, compl.	550 long, red	1
6	360 507-4	Sensor, compl.	450 long, black	1
6	360 527-4	Sensor, compl.	500 long, blue	1
	360 532-4	Switch, Level, compl.	LT 25/35 BT Rinsing zone	1
6	360 485-4	Sensor, compl.	505 long, red	1
6	360 511-4	Sensor, compl.	405 long, black	1
6	360 533-4	Sensor, compl.	455 long, blue	1
	353 812-4	Switch, Level, compl.	LT 50/60 BT Washing zone	1
6	353 815-4	Sensor, compl.	620 long, red	1
6	360 816-4	Sensor, compl.	525 long, black	1
6	360 817-4	Sensor, compl.	575 long, blue	1
	360 522-4	Switch, Level, compl.	LT 50/60 BT Rinsing zone	1
6	360 470-4	Sensor, compl.	575 long, red	1
6	360 500-4	Sensor, compl.	475 long, black	1
6	360 523-4	Sensor, compl.	525 long, blue	1
	360 540-4	Switch, Level, compl.	LT 70/90 BT, 50 CT W- and R-zone	1
6	360 497-4	Sensor, compl.	450 long, red	1
6	360 519-4	Sensor, compl.	350 long, black	1
6	360 541-4	Sensor, compl.	400 long, blue	1

TYPE		Parts Manual		Page
LT 25 , LT 35 LT 50 , LT 60 LT 70 , LT 90		LEVEL CONTROL OF WASHING TANK conductive		9-22.5
Pos.	Part N°	Part Name	Description	Quant.
		<u>Design for three levels</u>		
	360 536-4	Switch, Level, compl.	LT 35 CT W- and R-zone	1
6	360 493-4	Sensor, compl.	525 long, red	1
6	360 515-4	Sensor, compl.	425 long, black	1
6	360 537-4	Sensor, compl.	475 long, blue	1
1	353 595-4	Retainer		1
2	121 243	Catch, Bayonet		2
3	006 002	Hose	8 x 1	1
5	358 449-4	Seal	d=51 x d= 41 x 4	1
6		See above and page before		
7	137 644	Joint, Cable	Pg 7	3

LT 25 , LT 35
 TYPE LT 50 , LT 60
 LT 70 , LT 90

Parts List

DRAIN VALVE ASSEMBLY
 1. Version

Page
 9-23.0

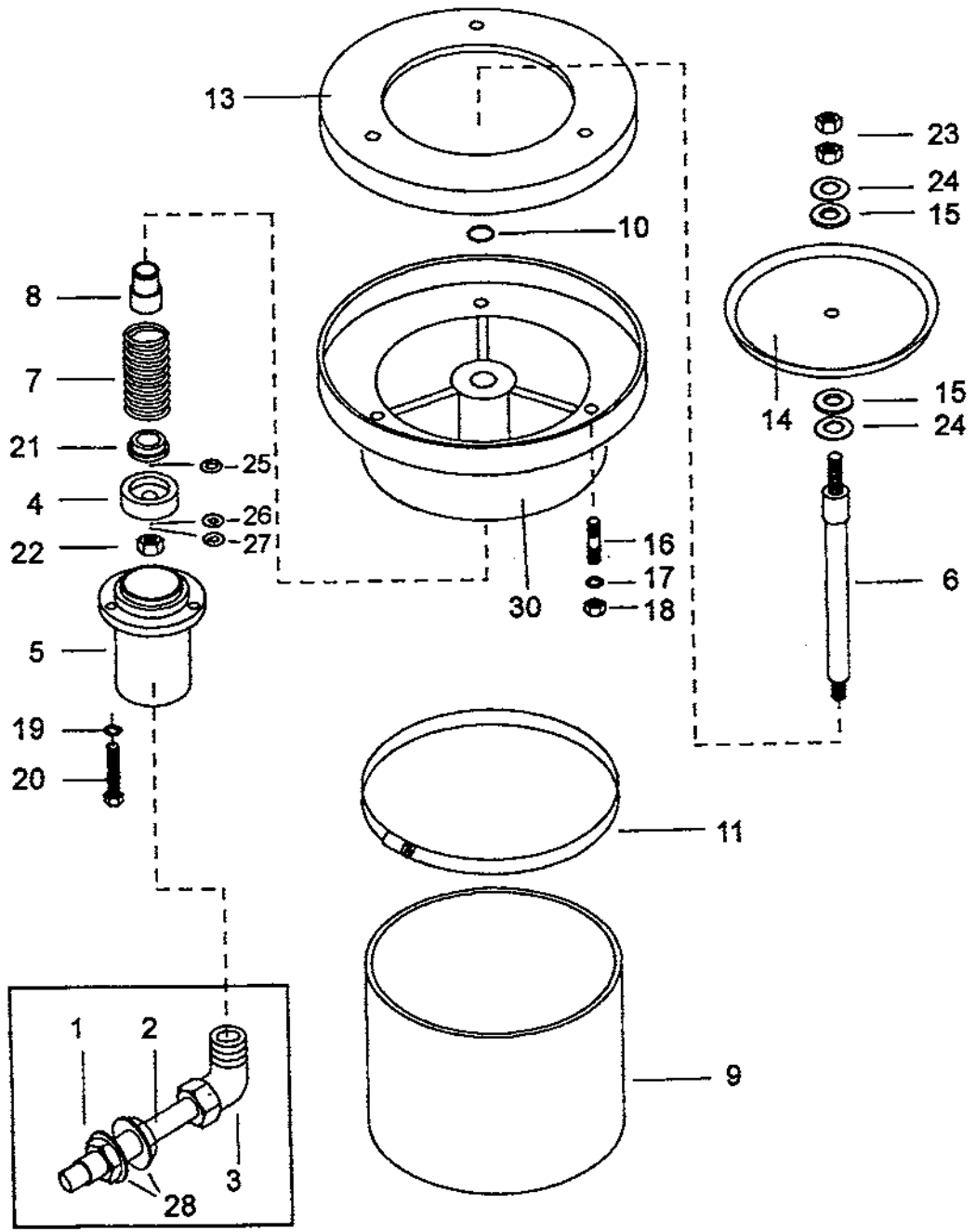

LT 25 , LT 35 TYPE LT 50 , LT 60 LT 70 , LT 90		Parts List DRAIN VALVE ASSEMBLY 1. Version		Page 9-23.1
Pos.	Part N°	Part Name	Description	Quant.
1-30	341 632-3	Valve, Drain compl. consisting of pos. 1 - 30		1
1	111 474	Fitting, Bulk Head	M 12 x 1,5 - 6/8	1
2	006 002	Hose, Plastic	8 x 1 x 50	1
3	112 003	Coupling, Elbow	G ¼ - 8/6	1
4	028 078	Piston, Assembly with SS Spring	TDuo 50 - 31	1
5	341 656-4	Housing, Cylinder		1
6	341653-4	Rod, Piston		1
7	027 018	Spring		1
8	341 652-4	Bushing		1
9	341 660-4	Collar		1
10	025 030	Ring, Snap	DIN 7993 A 22 x 2	1
11	121 108	Clamp, Hose	DIN 3017 B 1 - 179 x 15-W4	1
13	341 657-3	Seal		1
14	341 658-4	Seat, Valve		1
15	028 099	Seal	DIN 2690 6 PN 6 - OHA- PRESS	2
16	020 699	Stud	DIN 938 M 10 x 35 - A2-70	3
17	020 224	Washer, Lock	A 10 - A2	3

TYPE		Parts List			Page
LT 25 , LT 35 LT 50 , LT 60 LT 70 , LT 90		DRAIN VALVE ASSEMBLY 1. Version			9-23.2
Pos.	Part N°	Part Name		Description	Quant.
18	020 171	Nut, Hex	ISO 4032	M 10 - A2	3
19	020 374	Bolt, Hex	ISO 4017	M 6 x 50 - A2	3
20	020 055	Washer, Lock	DIN 128	A 6 - A2	3
21	341 654-4	Guide			1
22	020 038	Nut, Hex	ISO 4032	M 10 - 8 - A2K	1
23	020 171	Nut, Hex	ISO 4032	M 10 - A2	2
24	020 508	Washer	DIN 9021	A 10,5 - A2	2
25	028 265	O - Ring		10 x 2	1
26	020 052	Washer	DIN 125	10,5	1
27	020 224	Washer, Lock	DIN 128	A 10	1
28	020 507	Washer	DIN 125	A 13	2
30	349 618-3	Housing, Valve			1

TYPE LT 25 , LT 35
 LT 50 , LT 60
 LT 70 , LT 90

Parts List
DRAIN VALVE ASSEMBLY
 2. Version; (in case of sandy linen)

Page
 9-23.3

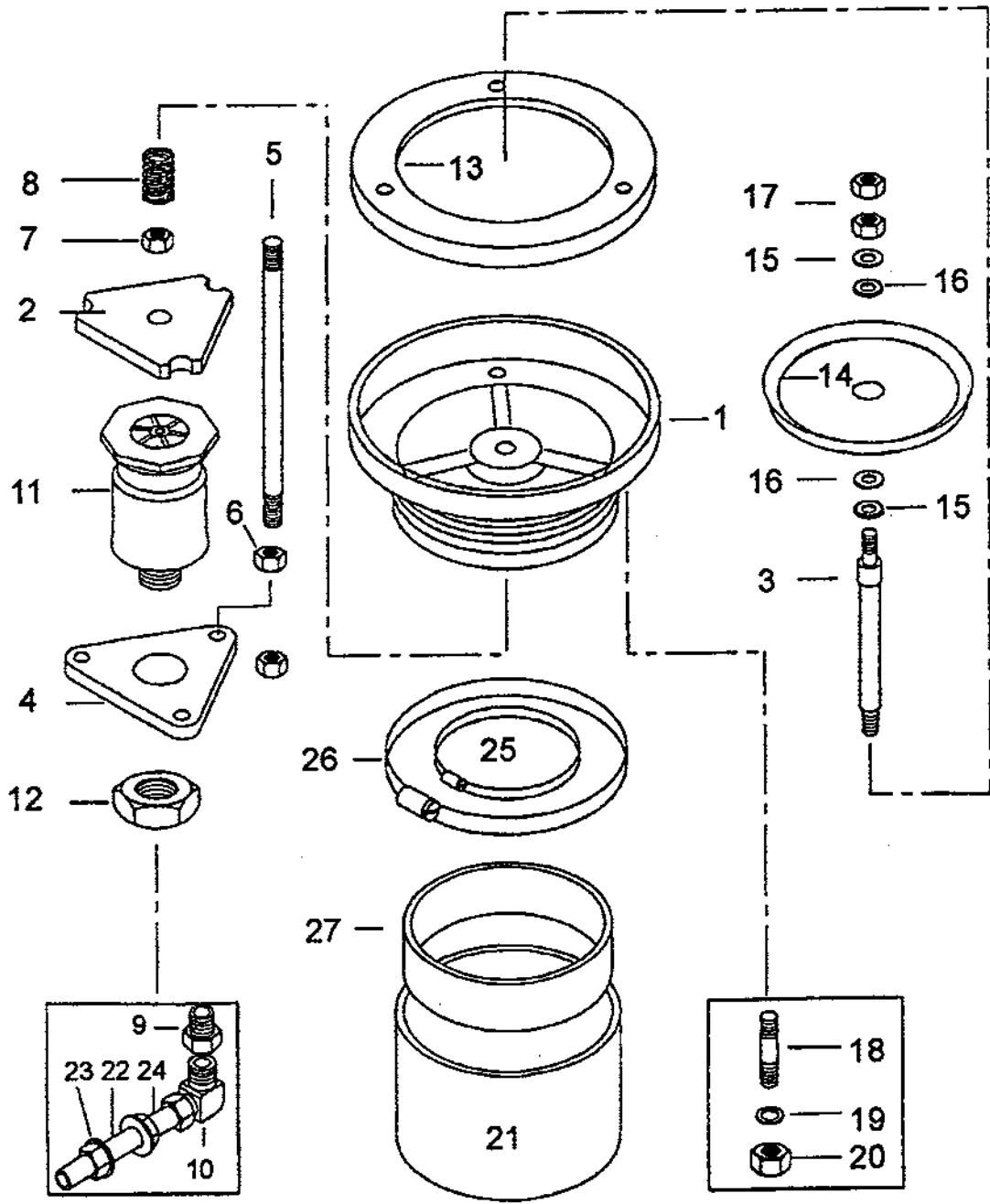

TYPE		Parts List			Page
LT 25 , LT 35 LT 50 , LT 60 LT 70 , LT 90		DRAIN VALVE ASSEMBLY 2. Version; (in case of sandy linen)			9-23.4
Pos.	Part N°	Part Name		Description	Quant.
1-27	345 531-2	Valve, Drain compl.			1
1	341 651-3	Housing, Valve			1
2	348 258-4	Washer, Guide			1
3	345 533-4	Rod, Piston			1
4	345 534-4	Plate, Drain Valve			1
5	348 259-4	Rod, Guide			1
6	020 031	Nut, Hex	ISO 4032	M 6 - A2	1
7	020 032	Nut, Hex	ISO 4032	M 8 - A2	1
8	027 032	Spring		VD 332	1
9	111 740	Nipple, Reducer		G 3/8 - G 1/4	1
10	112 003	Fitting, Elbow		G 1/4 - 3/8	1
11	111 789	Spring, Air		SZ 35 - 11	1
12	020 788	Nut, Hex	DIN 439	B M 30 x 1,5 - A2	1
13	341 657-3	Seal			1
14	341 658-4	Seat, Valve			1
15	020 508	Washer	DIN 9021	10,5	2
16	028 099	Seal	DIN 2690	6 - PN 6	2
17	020 171	Nut, Hex	ISO 4032	M 10 - A2	2
18	020 699	Stud	DIN 938	M 10 x 35-A2-70	3

TYPE		Parts List			Page
LT 25 , LT 35 LT 50 , LT 60 LT 70 , LT 90		DRAIN VALVE ASSEMBLY 2. Version; (in case of sandy linen)			9-23.5
Pos.	Part N°	Part Name		Description	Quant.
19	020 224	Washer, Lock	DIN 128	A 10 - 1.4310	3
20	020 171	Nut, Hex	ISO 4032	M 10 - A2 - 70	3
21	341 660-4	Collar			2
22	111 474	Fitting, Bulk Head		N° 12.0531	1
23	020 507	Washer	DIN 125	13 - A2	2
24	006 002	Hose		8 x 1 x 50	1
25	121 028	Clamp, Hose	DIN 3017	AS 50 - 70 - W3	4
26	121 001	Clamp, Hose	DIN 3017	AS 110 - 130 - W3	4
27	341 754-4	Pipe			1

TYPE LT 25 , LT 35
LT 50 , LT 60
LT 70 , LT 90

Parts List

SEALS, RUBBER
Drum / Liquor Tank

Page
9-24.0

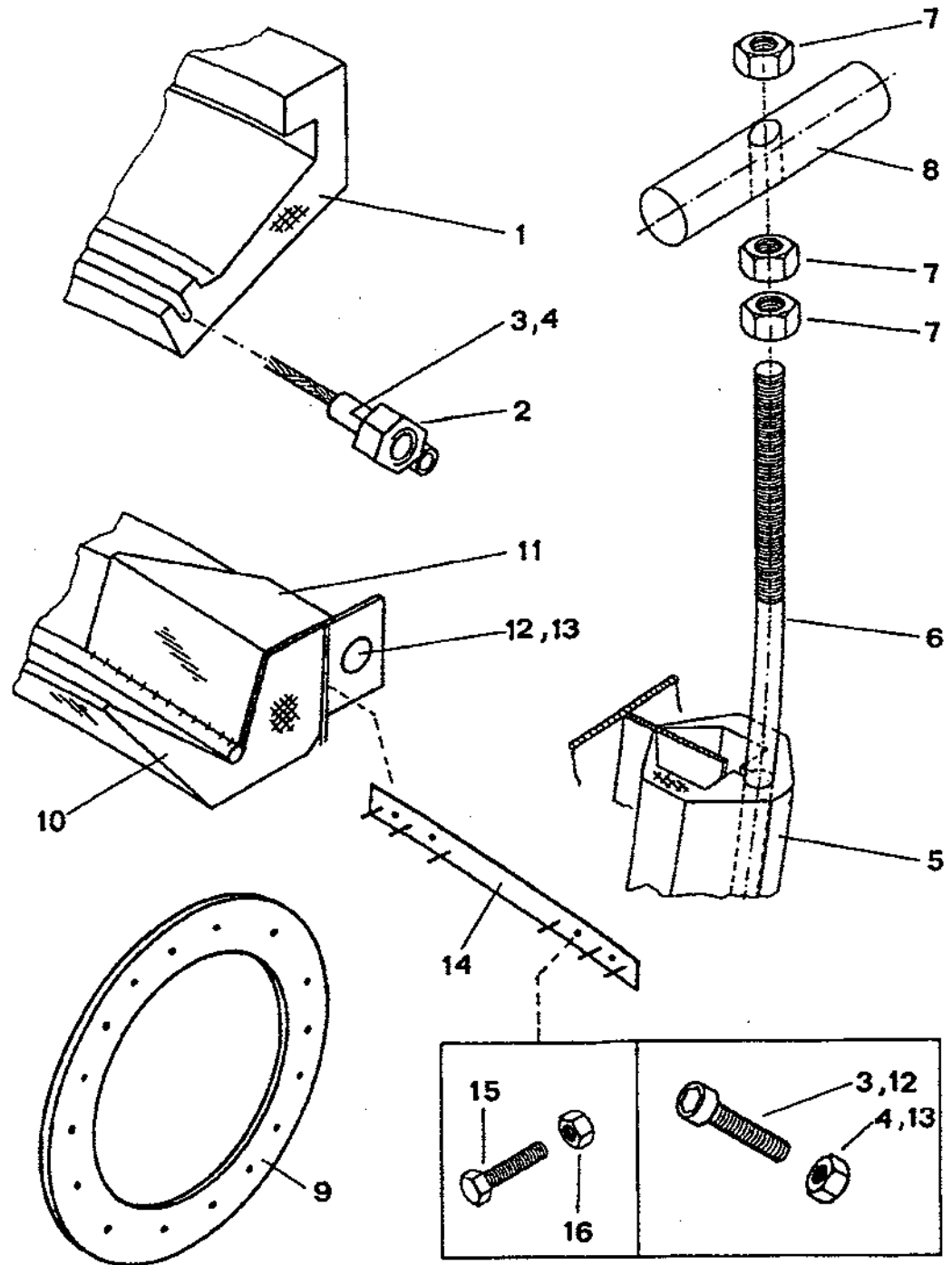

TYPE		Parts List		Page
LT 25 , LT 35 LT 50 , LT 60 LT 70 , LT 90		SEALS, RUBBER Drum / Liquor Tank		9-24.1
Pos.	Part N°	Part Name	Description	Quant.
1	352 906-4	Seal, outside (Tank end seal)	L = 6600	2
		<u>NOTE:</u> Tank end seal pos. 1, length matched during assembling		
2	343 279-4	Rope, compl.	25 BT, 35 BT	2
2	343 280-4	Rope, compl.	50/60 BT, 35 CT	2
2	352 907-4	Rope, compl.	50 CT, 70/90 BT	2
3	020 648	Bolt, Allan	ISO 4762 A M8 x 80-A2-70	2
4	020 032	Nut, Hex	ISO 4032 M8 - A2	2
5	358 887-4	Seal, inside	L= 2365 for 25/35 BT	*)
5	358 888-4	Seal, inside	L = 2575 for 50 BT 60 BT, 35 CT	*)
5	358 889-4	Seal, inside	L = 2750 for 50 CT and 70/90 BT	*)
		*) Quant. pos. 5 acc. to the number of compartments		
		<u>NOTE:</u> Sealing of compartments in old version see pos. 10 - 16		

TYPE		Parts List		Page
LT 25 , LT 35 LT 50 , LT 60 LT 70 , LT 90		SEALS, RUBBER Drum / Liquor Tank		9-24.2
Pos.	Part N°	Part Name	Description	Quant.
6	343 003-4	Retainer, Seal	25/35 BT	1) ¹⁾
6	343 005-4	Retainer, Seal	50/BT, 35 CT	1) ¹⁾
6	352 925-4	Retainer, Seal	50 CT, 70/90 BT	1) ¹⁾
7	020 171	Nut, Hex ISO 4032	M 10 - A2	6 ²⁾
8	347 727-4	Log, Tightening		2 ²⁾
<hr/> <p>1) Quant. pos. 6 acc. to the number of compartments 2) multiply with quantity pos. 5</p>				
<u>CHUTE / DRUM</u>				
9	340 072-4	Seal, Chute-Ø 685 only for serial N° 25001 - 25023, 35001 - 35121 and 35124	5 x 638 x 822 LT 25/35 BT	1
9	348 254-4	Seal, Chute-Ø 700 only for serial N° 25024, 25025, 35122, 35123, 35125 + 35126	5 x 700 x 822 LT 25/35 BT	1
9	350 685-4	Seal, Chute-Ø 700 only for serial N° 25026-25035, 35127 - 35147, 35149 - 35158, 35160 + 35161, 35163, 35169 - 35171, 35173 - 35176	5 x 666 x 850 LT 25/35 BT	1

TYPE		Parts List		Page
LT 25 , LT 35 LT 50 , LT 60 LT 70 , LT 90		SEALS, RUBBER Drum / Liquor Tank		9-24.3
Pos.	Part N°	Part Name	Description	Quant.
9	340 116-4	Seal, Chute-Ø 800 for serial N° 35148, 35162, 35164 - 35168, 35172, from 35177 - from 25036 - only for N° 50001 - 50268, 50270 - 50336, 50338 + 50339, 50341 - 50345, 50347 - 50349	5 x 751 x 935 LT 25/35 BT LT 50 BT	1
9	354 534-4	Seal, Chute-Ø 900 for serial N° 35159 from serial N° 35181 for 35 CT	5 x 851 x 1035 LT 35 CT	1
9	354 534-4	Seal, Chute-Ø 900 for serial N° 50337, 50346, from 50350 -	5 x 851 x 1035 LT 50/60 BT LT 50 CT	1
9	351 696-4	Seal, Chute-Ø 950 for serial N° 50269 and 50340 (LAVATRAC for mats)	5 x 905 x 1089 LT 50 BT	1
9	357 842-4	Seal, Chute-Ø 1100	5 x 1053 x 1237 LT 70/90 BT	1

LT 25 , LT 35 TYPE LT 50 , LT 60 LT 70 , LT 90	Parts List SEALS, RUBBER Drum / Liquor Tank	Page 9-24.4
---	--	--------------------

Pos.	Part N°	Part Name	Description	Quant.
		<u>Sealing of compartments in old version, valid for:</u> LT 25 : Serial N°. 25002 - 25004 LT 35 : up to serial N° 35101 LT 50 : up to serial N° 50178 and also N°. 50181 + 50182		
10	340 050-4	Seal, inside length matched during assembling	L = 5600	1)
11	342 580-3	Strap, Tightening, compl.	LT 25 + 35	2 ²⁾
11	342587-3	Strap, Tightening, compl.	LT 50	2 ²⁾
12	020 648	Bolt, Allan ISO 4762	M8 x 80 - A2-70	2 ²⁾
13	020 032	Nut, Hex ISO 4032	M8 - A2	4 ²⁾
14	903 712	Clamp	SK 211188	1 ²⁾
15	020 404	Bolt, Hex ISO 4017	M 6 x 30 - A2 - 70	4 ²⁾
16	020 031	Nut, Hex ISO 4032	M 6 - A2	4 ²⁾
		1) Quantity acc. to the number of compartments 2) multiply quantities pos. 11 - 16 with quantity pos. 10 NOTE: Sealing of compartments in new version see pos. 5 - 8		

LT 25 , LT 35
TYPE LT 50 , LT 60
LT 70 , LT 90

Parts List

PNEUMATIC SYSTEM

Page
9-25.0

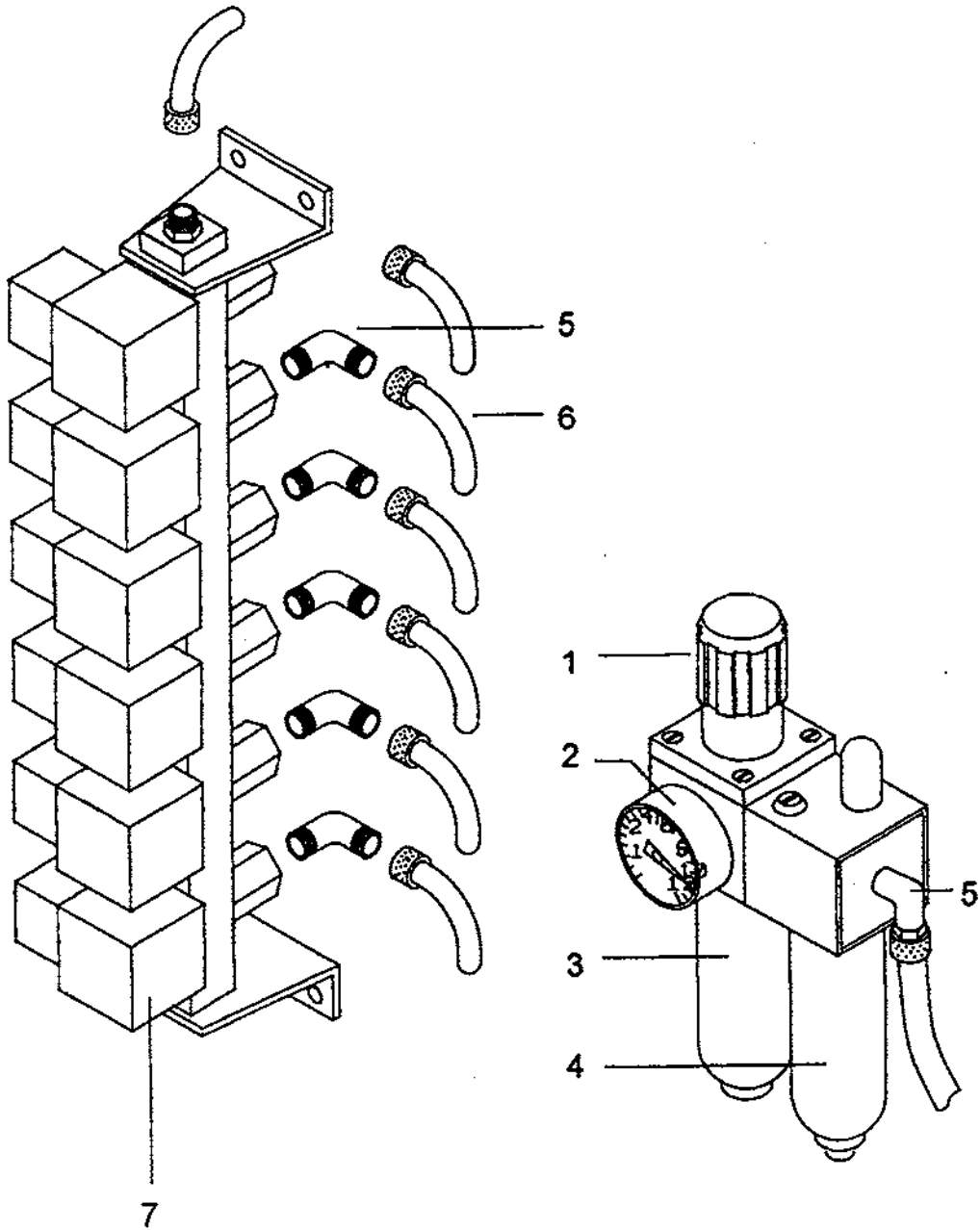

TYPE		Parts List		Page
LT 25 , LT 35 LT 50 , LT 60 LT 70 , LT 90		PNEUMATIC SYSTEM		9-25.1
Pos.	Part N°	Part Name	Description	Quant.
1	111 063	Regulator, Pressure consisting of pos. 2 - 5		1
2	111 555	Manometer	0 - 10 bar-G 1/8	1
3	111 395	Glas, Spare for Filter		1
4	111 396	Glas, Spare for Oiler		1
5	111 077	Coupling, Elbow	G ¼ - 8/6	
6	006 002	Hose, Plastic	8 x 1, indicate length	
7	111 278	Valve, 230 V, 50 Hz	9 933 402.0200	1), 2)
7	111 277	Valve, 230 V, 50 Hz	9 933 412.0200	1), 3)
7	111 160	Valve, 115 V, 60 Hz	9 933 402.0200	1), 2)
7	111 161	Valve, 115 V, 60 Hz	9 933 412.0200	1), 3)
7	111 893	Valve, 220 V, 60 Hz	9 933 402.0200	1), 2)
7	111 894	Valve, 220 V, 60 Hz	9 933 412.0200	1), 3)
7	111 135	Valve, 24 V, 50 Hz	9 933 402.0200	1), 2)
7	111 692	Valve, 24 V, 50 Hz	9 933 412.0200	1), 3)
		1) Quantity and type as per LAVATRAC version 2) closed in OFF-Pos. 3) opened in OFF-Pos.		

TYPE LT 25 , LT 35 LT 50 , LT 60 LT 70 , LT 90	Parts List AUTOMATIC LINT SEPARATOR »LAVALINT«	Page 9-26.0
--	---	-----------------------

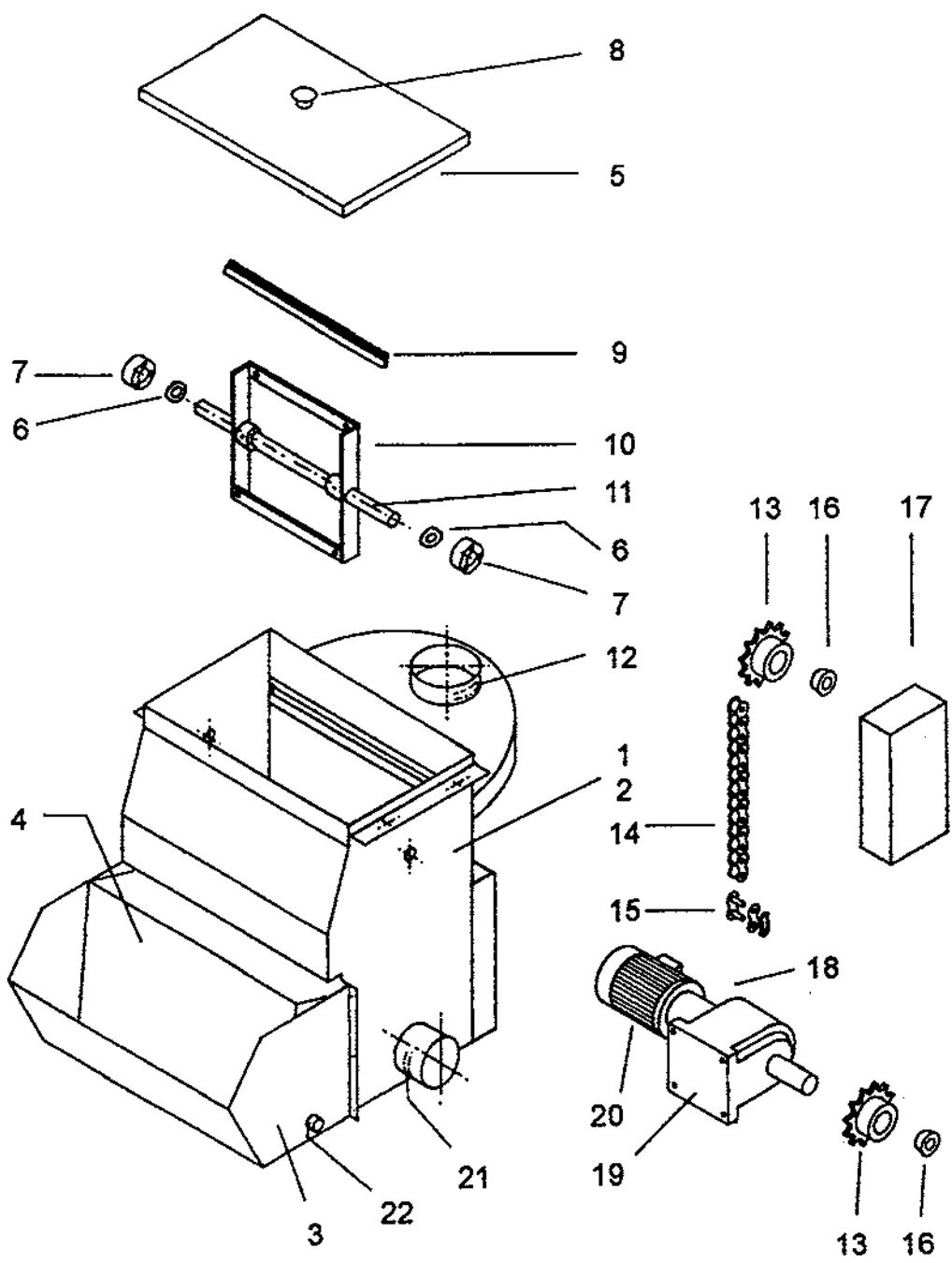

TYPE		Parts List		Page
LT 25 , LT 35 LT 50 , LT 60 LT 70 , LT 90		AUTOMATIC LINT SEPARATOR Typ LL 9 For LT's with output up to 1800 kg dry linen/h		9-26.1
Pos.	Part N°	Part Name	Description	Quant.
1	343 199-1	Separator, Lint compl. consisting of pos. 1 - 22		1
2	343 200-1	Housing		1
3	343 213-3	Cage		1
4	343 221-4	Container, Lint		1
5	341 327-3	Cover, Top		1
6	021 005	Washer	DIN 125 A 21 - 140 HV - A2	2
7	343 236-4	Bearing		2
8	125 003	Handle	33 - M 8	1
9	125 021	Brush	Alu / Nylon - 500	2
10	343 225-3	Holder, Brush		1
11	351 721-4	Shaft		1
12	121 001	Clamp, Hose	DIN 3017 AS 110 - 130 - W3	1
13	103 150	Wheel, Chain	041 - 15	2
14	006 901	Chain	ISO-N°. 08 B-1,1/2	1
15	103 101	Link, Chain		1
16	103 151	Hub, Lock	TL 1008 - 20	2
17	348 899-3	Guard, Chain		1

TYPE		Parts List		Page
LT 25 , LT 35 LT 50 , LT 60 LT 70 , LT 90		AUTOMATIC LINT SEPARATOR Typ LL 9 For LT's with output up to 1800 kg dry linen/h		9-26.2
Pos.	Part N°	Part Name	Description	Quant.
18	107 277	Motor, Gear compl. consisting of pos. 19 + 20 220-240/380-415 V 50 Hz, 243-277/420-480 V 60 Hz	Typ 3 G 90/71/4 D 71 A 4-6 Indicate other types of current	1
19	-	Box, Gear for pos. 18		1
20	-	Motor for pos. 18	Indicate type, kW and type of current	1
21	121 150	Clamp, Hose DIN 3017	B1 - 116 x 15 - W4	2
22	121 029	Clamp, Hose DIN 3017	AS 32 - 50 - W3	1

TYPE		Parts List		Page
LT 25 , LT 35 LT 50 , LT 60 LT 70 , LT 90		AUTOMATIC LINT SEPARATOR Typ LL 18 For LT's with output more than 1800 kg dry linen/h		9-26.3
Pos.	Part N°	Part Name	Description	Quant.
1	344 055-1	Separator, Lint compl. consisting of pos. 1 - 22		1
2	344 142-1	Housing		1
3	344 151-3	Cage		1
4	344 153-4	Container, Lint		1
5	344 159-3	Cover, Top		1
6	021 005	Washer	DIN 125 A 21 - 140 HV - A2	2
7	343 236-4	Bearing		2
8	125 003	Handle	33 - M 8	1
9	125 021	Brush	Alu / Nylon - 500	4
10	344 155-3	Holder, Brush		1
11	360 611--	Shaft		1
12	121 145	Clamp, Hose	DIN 3017 Torro13 C6 W3/140-160	1
13	103 150	Wheel, Chain	041 - 15	2
14	006 901	Chain	ISO-N° 08 B-1,1/2	1
15	103 101	Link, Chain		1
16	103 151	Hub, Lock	TL 1008 - 20	2
17	348 899-3	Guard, Chain		1

TYPE		Parts List		Page	
LT 25 , LT 35 LT 50 , LT 60 LT 70 , LT 90		AUTOMATIC LINT SEPARATOR Typ LL 18 For LT's with output more than 1800 kg dry linen/h		9-26.4	
Pos.	Part N°	Part Name		Description	Quant.
18	107 277	Motor, Gear compl. consisting of pos. 19 + 20 220-240/380-415 V 50 Hz, 243-277/420-480 V 60 Hz		Typ 3 G 90/71/4 D 71 A 4-6 Indicate other types of current	1
19	-	Box, Gear for pos. 18			1
20	-	Motor for pos. 18		Indicate type, kW and type of current	1
21	121 246	Clamp, Hose	DIN 3017	S 131 / 15 SZ W5	2
22	121 029	Clamp, Hose	DIN 3017	AS 32 - 50 - W3	1

TYPE LT 25 , LT 35
LT 50 , LT 60
LT 70 , LT 90

Parts Manual

CONTROL PANEL DOSING

Page
9-27.0

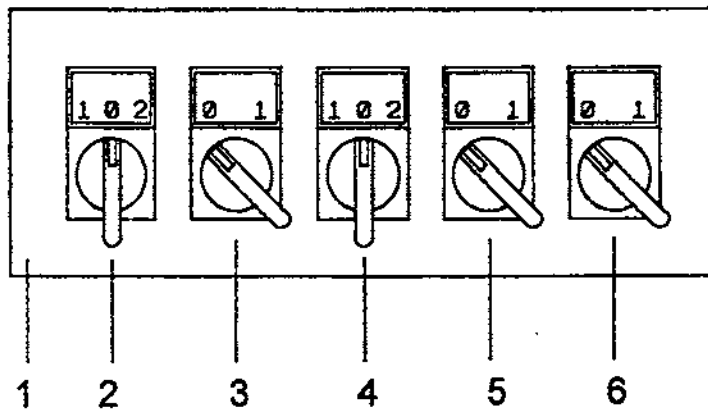

TYPE LT 25 , LT 35 LT 50 , LT 60 LT 70 , LT 90		Parts Manual CONTROL PANEL DOSING	Page 9-27.1	
Pos.	Part N°	Part Name	Description	Quant.
		<p><u>NOTE :</u></p> <p>For part numbers and description see wiring diagram</p>		

LT 25 , LT 35
TYPE LT 50 , LT 60
LT 70 , LT 90

Parts Manual

DOSING SYSTEM DETERGENT

Page
9 - 28.0

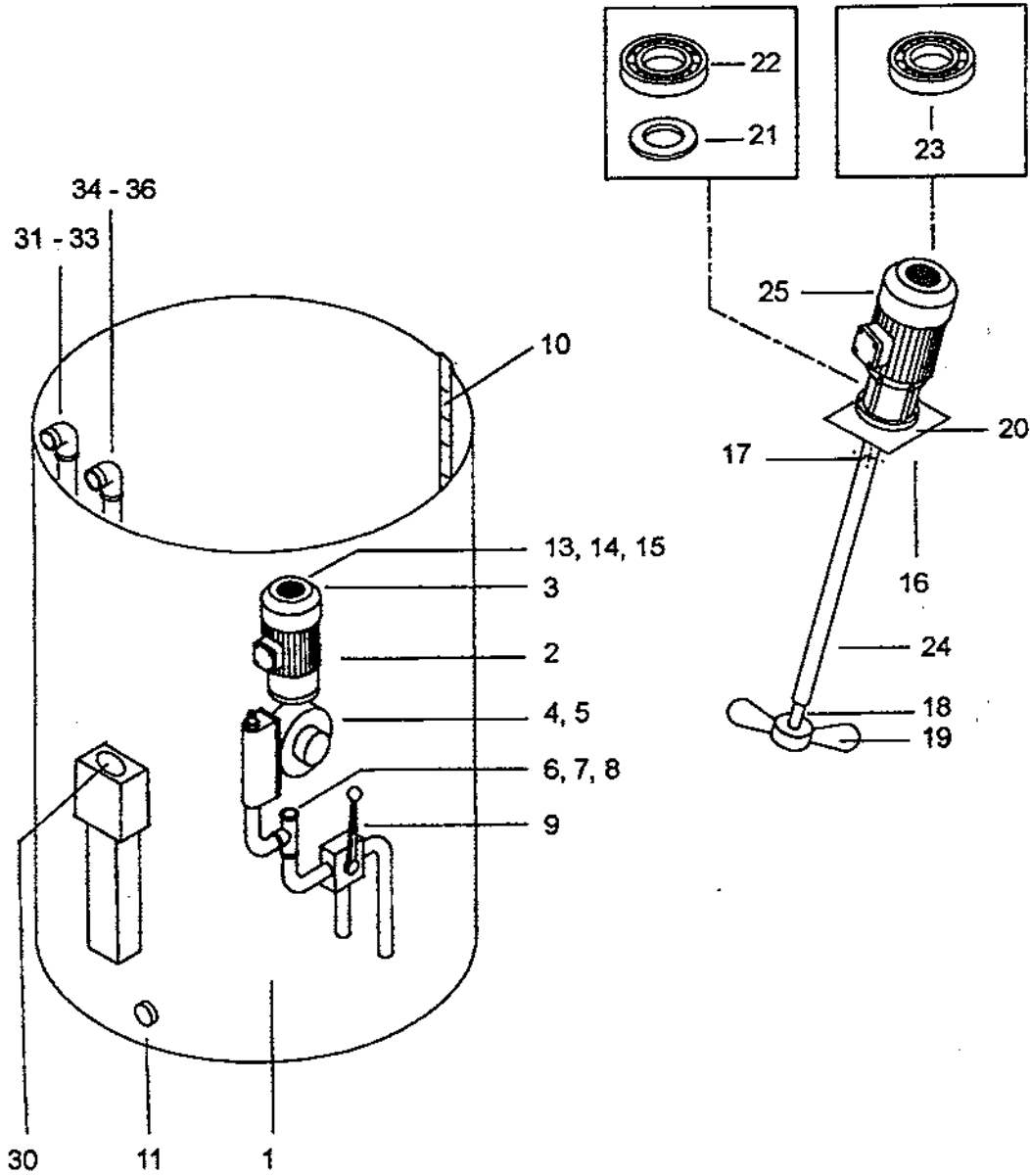

LT 25 , LT 35 TYPE LT 50 , LT 60 LT 70 , LT 90		Parts Manual DOSING SYSTEM DETERGENT		Page 9-28.1
Pos.	Part N°	Part Name	Description	Quant.
1	-	Tank, Detergent	Size as per order	1
2	111 268	Pump, compl. consisting of pos. 3 - 5	MR 290 - SAL indicate voltage and kW	*)
3	-	Motor	Indicate type, voltage and kW	*)
4	-	Pump	PTFE	*)
5	-	Membrane		*)
6	341 288-4	Filter		*)
7	028 120	O - Ring	30 x 4	*)
8	341 289-4	Plug		*)
9	111 689	Valve, Three-way	G ¾ - PN 40	*)
10	342 544-4	Stick, Measuring	800 L	*)
10	343 387-4	Stick, Measuring	1150 L	1
10	342 585-4	Stick, Measuring	1500 L	1
11	030 123	Plug	DIN 2991 S 1 - 1.4301	1
13	342 586-4	Cover		1
14	903 628	Clamp	501 R - 10 x 520	*)
15	903 629	Lock	540 R - gA	*)
*) : as per tank version 1 - 3 pieces				*)

TYPE		Parts Manual		Page
LT 25 , LT 35 LT 50 , LT 60 LT 70 , LT 90		DOSING SYSTEM DETERGENT Stirrer		9-28.2
Pos.	Part N°	Part Name	Description	Quant.
16	-	Stirring System compl.	Indicate stirrer type, voltage and tank size	1
17	-	Pin, Roll		1
18	-	Shaft		1
19	-	Propeller		1
20	-	Clamp		1
21	-	Seal		1
22	-	Bearing, Ball		1
23	-	Bearing, Ball		1
24	-	Protector		1
25	-	Motor	Indicate type and voltage	1
<p>NOTE: Indicate type of stirrer if you ordering pos. 17 - 25, see also spare parts list of the stirrer manufacturer.</p>				

LT 25 , LT 35 TYPE LT 50 , LT 60 LT 70 , LT 90	Parts Manual DOSING SYSTEM DETERGENT Heating	Page 9-28.3
---	---	----------------

Pos.	Part N°	Part Name	Description	Quant.
<u>Only for heated tanks</u>				
30	135 010	Thermostat	OS 105-0	1
31	111 166	Valve, Straight-way	514-20-D1- 37-5-1-3	1
32	111 149	Valve, Control	220 V, 50 Hz	1
32	111 161	Valve, Control	115 V, 60 Hz	1
33	006 002	Hose, Air	259.120 - 8 x 1	1
<u>Accessories for indirectly heated tanks</u>				
34	118 007	Trap, Steam, compl.	MK 35 / 31	1
35	118 126	Membrane for pos. 34		1
36	-	Filter, Dirt for pos. 34		1

LT 25 , LT 35
TYPE LT 50 , LT 60
LT 70 , LT 90

Parts List

DOSING SYSTEM STARCH

Page

9-29.0

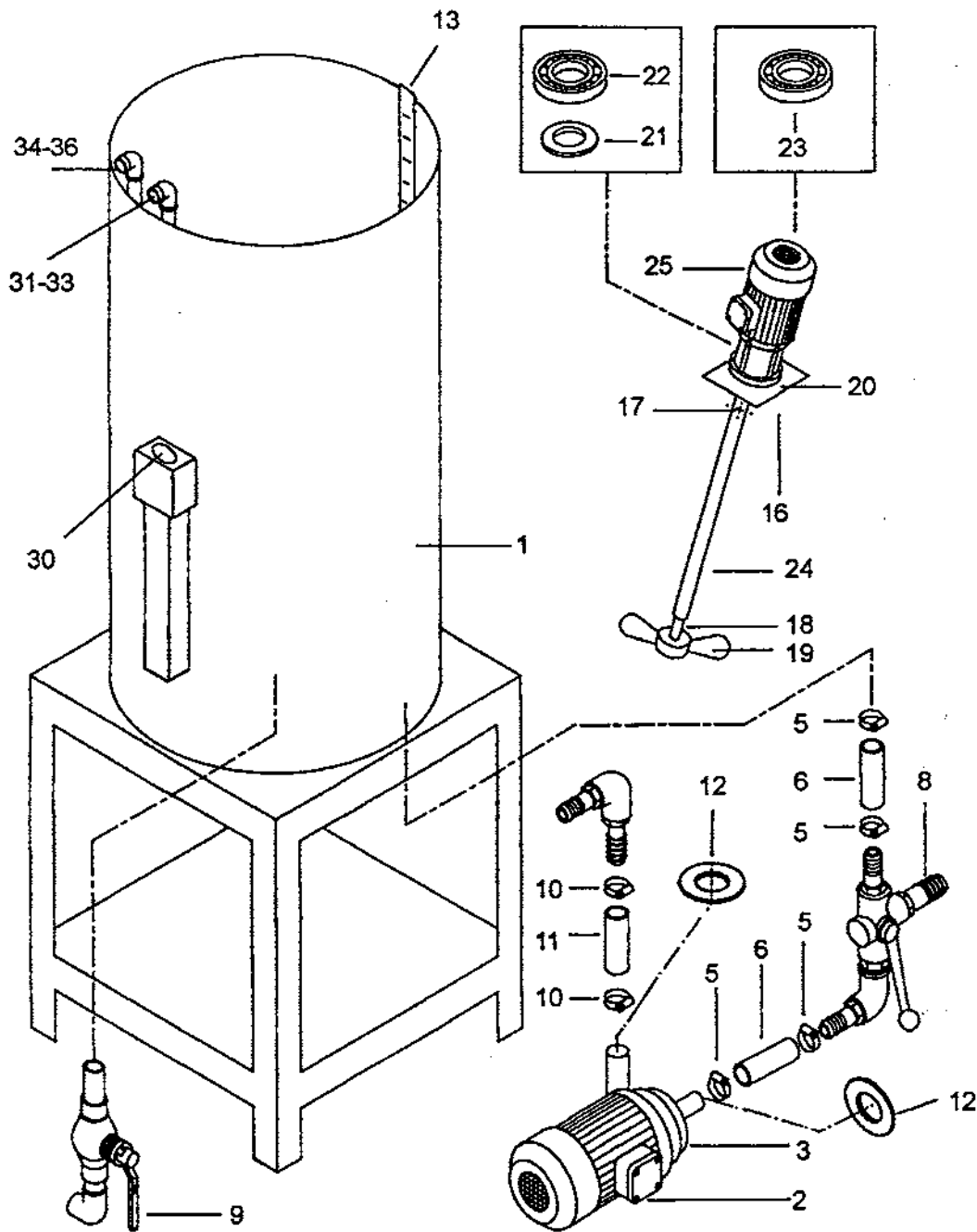

TYPE		Parts List		Page
LT 25 , LT 35 LT 50 , LT 60 LT 70 , LT 90		DOSING SYSTEM STARCH Cold Starch		9-29.1
Pos.	Part N°	Part Name	Description	Quant.
		Only for unheated starch tanks <u>„Cold Starch“</u>		
1	-	Tank, Starch	Size as per order	1
2	111 339	Pump, Centrifugal	KNM 251-2/1,1 indicate voltage	1
3	111 301	Seal, Packing for pos. 2		1
5	121 028	Clamp, Hose	DIN 3017	4
6	006 014	PVC-Hose	50 x 5 x 100	2
8	111 489	Valve, Three-way	51 958-DN 40- PN 10	1
9	111 152	Valve, Ball	G 1	1
10	121 029	Clamp, Hose	DIN 3017	2
11	006 033	Hose	35 x 4 x 100	1
13	341 964-4	Stick, Measuring	200 L	1
13	346 272-4	Stick, Measuring	300 L	1
13	345 169-4	Stick, Measuring	400 L	1
13	342 545-4	Stick, Measuring	800 L	1

TYPE		Parts List		Page
LT 25 , LT 35 LT 50 , LT 60 LT 70 , LT 90		DOSING SYSTEM STARCH Hot Starch		9-29.2
Pos.	Part N°	Part Name	Description	Quant.
		Only for starch tanks with heating device		
		<u>„Hot Starch“</u>		
1	-	Tank, Starch	Size as per order	
2	-	Pump, Centrifugal	Hygia-Block I-20b indicate voltage	1
3	-	Seal, Packing for pos. 2		1
5	121 028	Clamp, Hose DIN 3017	50 - 70	4
6	006 015	Hose, Textile Rubber	50 x 8 x 120	2
8	-	Valve, Three-way	KH 1082 T-Ms- DN 40	1
9	111 152	Valve, Ball	G 1	1
12	028 019	Gasket DIN 2690 (only for pump with flange connection)	50 PN 40	2
13	341 964-4	Stick, Measuring	200 L	1
13	346 272-4	Stick, Measuring	300 L	1
13	345 169-4	Stick, Measuring	400 L	1
13	342 545-4	Stick, Measuring	800 L	1

TYPE		Parts List		Page
LT 25 , LT 35 LT 50 , LT 60 LT 70 , LT 90		DOSING SYSTEM STARCH Stirrer		9-29.3
Pos.	Part N°	Part Name	Description	Quant.
16	-	Stirring System compl.	Indicate stirrer type, voltage and tank size	1
17	-	Pin, Roll		1
18	-	Shaft		1
19	-	Propeller		1
20	-	Clamp		1
21	-	Seal		1
22	-	Bearing, Ball		1
23	-	Bearing, Ball		1
24	-	Protector		1
25	-	Motor	Indicate type and voltage	1
<p>NOTE: Indicate type of stirrer if you ordering pos. 17 - 25, see also spare parts list of the stirrer manufacturer.</p>				

TYPE		Parts List		Page
LT 25 , LT 35 LT 50 , LT 60 LT 70 , LT 90		DOSING SYSTEM STARCH Heating		9-29.4
Pos.	Part N°	Part Name	Description	Quant.
<u>Only for heated tanks</u>				
30	135 010	Thermostat	OS 105-0	1
31	111 166	Valve, Straight-way	514-20-D1- 37-5-1-3	1
32	111 149	Valve, Control	220 V, 50 Hz	1
32	111 161	Valve, Control	115 V, 60 Hz	1
33	006 002	Hose, Air	259.120 - 8 x 1	1
<u>Accessories for Indirectly heated tanks</u>				
34	118 007	Trap, Steam, compl.	MK 35 / 31	1
35	118 126	Membrane for pos. 34		1
36	-	Filter, Dirt for pos. 34		1

<p>TYPE</p> <p>LT 25 , LT 35 LT 50 , LT 60 LT 70 , LT 90</p>	<p>Parts List</p> <p>DOSING SYSTEM AUXILIARY CHEMICALS</p>	<p>Page</p> <p>9-30.0</p>
---	--	---------------------------

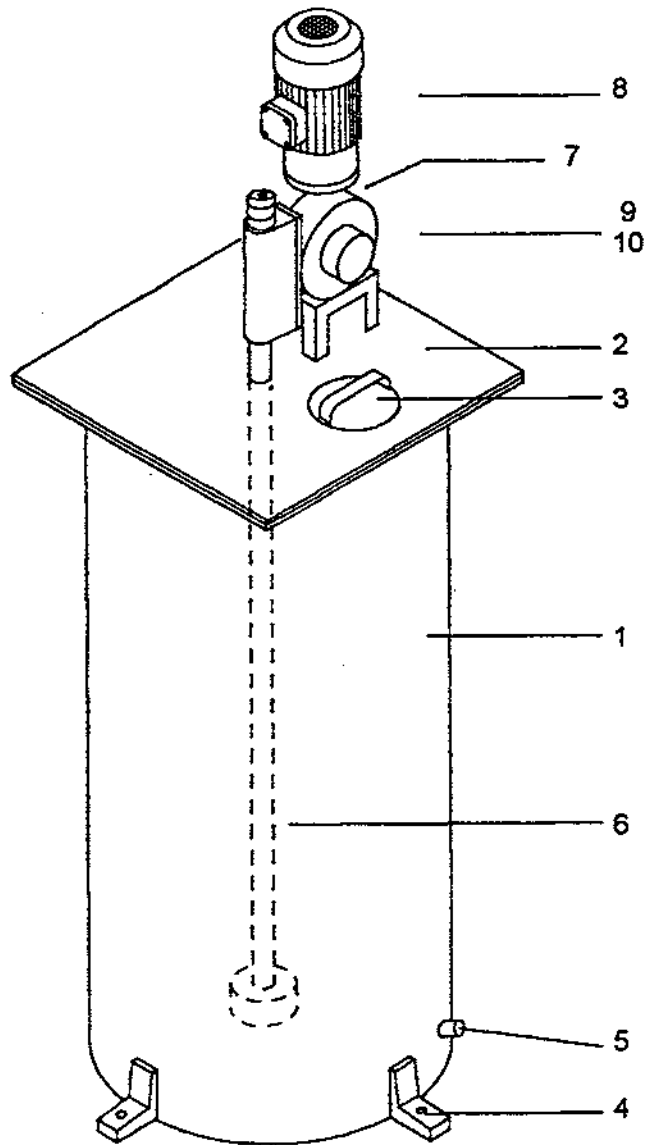

TYPE		Parts List		Page
LT 25 , LT 35 LT 50 , LT 60 LT 70 , LT 90		DOSING SYSTEM AUXILIARY CHEMICALS		9-30.1
Pos.	Part N°	Part Name	Description	Quant.
1	-	Tank, transparent	300 L - PE	1
2	-	Plate, Cover	710 x 710	1
3	-	Cover, Inspection	Ø 180	1
4	-	Foot		3
5	-	Plug	G ¾	1
6	-	Pipe, Suction	SB - DN 15 - PVC	1
7	-	Membrane, Dosing Pump consisting of pos. 8 - 10	MR 210 indicate voltage	1
8	-	Motor	Indicate type and voltage	1
9	-	Pumpe		1
10	-	Membrane		1

LT-25,35,50,60,70,90 BT LT-25,35,50,60,70,90 CT	PNEUMATIKSYSTEM PNEUMATIC SYSTEM SYSTEME PNEUMATIQUE	Blatt Page 9-31.0
--	--	-------------------------

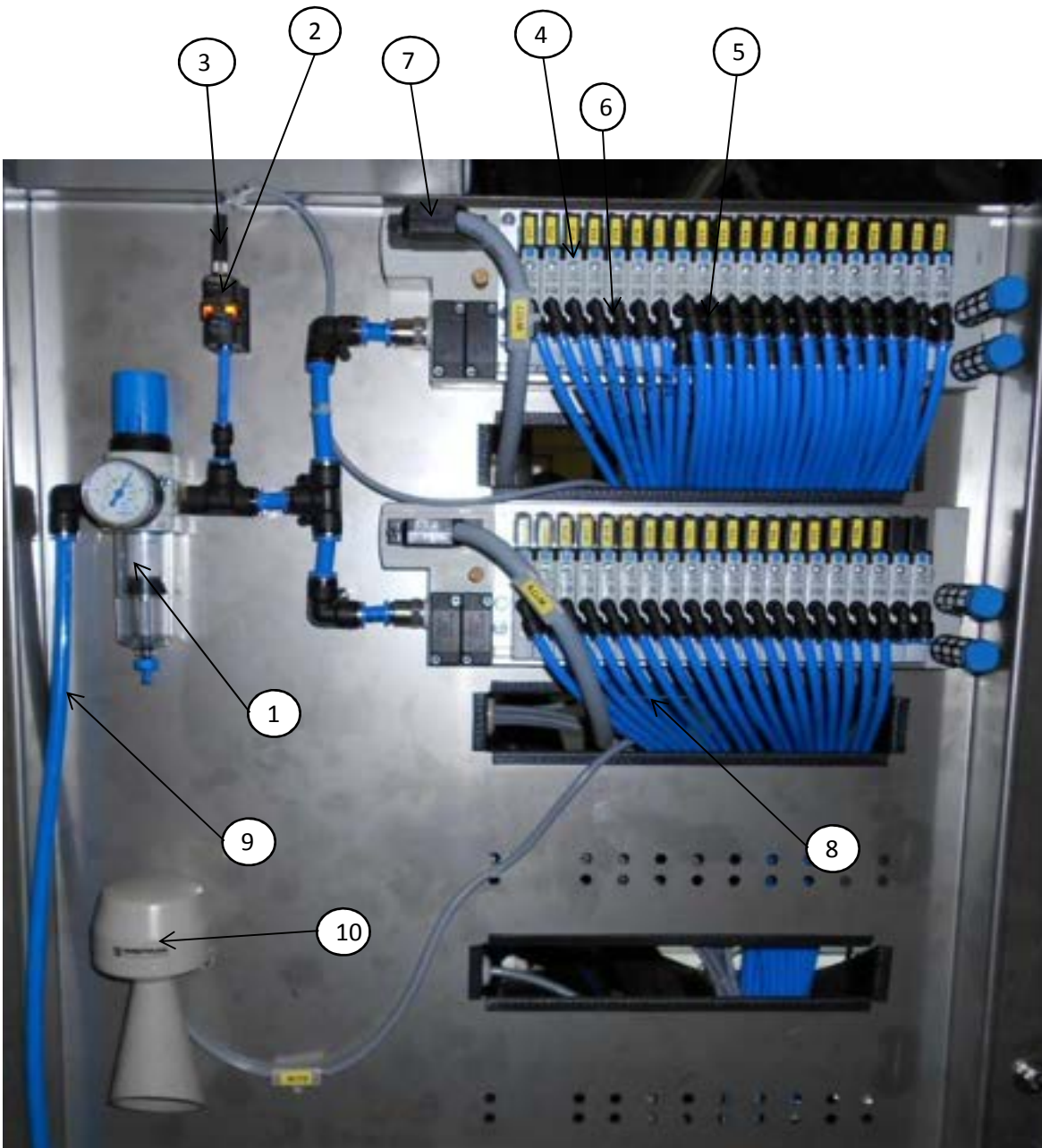

LT-25,35,50,60,70,90 BT LT-25,35,50,60,70,90 CT		Ersatzteilliste, Spare parts list, Liste de pièces PNEUMATIKSYSTEM PNEUMATIC SYSTEM SYSTEME PNEUMATIQUE		Blatt Page 9-31.1
POS. REP.	Ident-Nr. Part No. Ref. N°	Benennung Part Name Désignation	Bezeichnung Description	Menge Quant.
1	113312	Filterregelventil filter-control valve filtre-régulateur-soupape	Festo	1
2	113319	Drucksensor Pressure sensor pression capteur	Festo	1
3	138908	Kabel Cable Câble	Festo	1
4	133304	Ventil Valve Soupape	Festo	
5	113306	Steckanschluß Ventil 6mm cartridge valve 6mm borne à fiche soupape 6mm	Festo	
6	113305	Steckanschluß Ventil 6mm cartridge valve 6mm borne à fiche soupape 6mm	Festo	
7	138913	Kabel 45° Cable 45° Câble 45°		
8	6082	Schlauch 6 hose 6 Tuyau 6	Festo	
9	6137	Schlauch 10 hose 10 Tuyau 10	Festo	
10	136243	Signalhupe signal horn signal cornet	werma	1